



DEMAG CC8800-1 | Crawler Crane 1600 t Lifting Capacity

PRELIMINARY
VORLÄUFIG
PROVISOIRE



DEMAG CC8800-1
CRAWLER CRANE

DEMAG CC8800-1 HIGHLIGHTS

- ▶ Max. capacity 1600 t
- ▶ Max. load moment 24002 mt
- ▶ Superlift radii 19-30 m
- ▶ Excellent capacities at the luffing fly jib
- ▶ Redundant drivelines
- ▶ 400 V power supply
- ▶ Optional TWIN-Kit for capacities up to 3200 t

- ▶ Max. Tragfähigkeit 1600 t
- ▶ Max. Lastmoment 24002 mt
- ▶ Superliftradien 19-30 m
- ▶ Ausgezeichnete Tragfähigkeiten am wippbaren Hilfsausleger
- ▶ Redundante Antriebseinheiten
- ▶ 400 V Stromaggregat
- ▶ Optionales TWIN-Kit für Tragfähigkeiten bis 3200 t

- ▶ Capacité maximale de 1600 t
- ▶ Moment de charge maximum 24002 mt
- ▶ Radius superlift 19-30 m
- ▶ Excellentes capacités avec la volée variable
- ▶ Double unité d'entraînement
- ▶ Groupe électrogène de 400 V
- ▶ En option le kit TWIN pour des capacités jusqu'à 3200 t

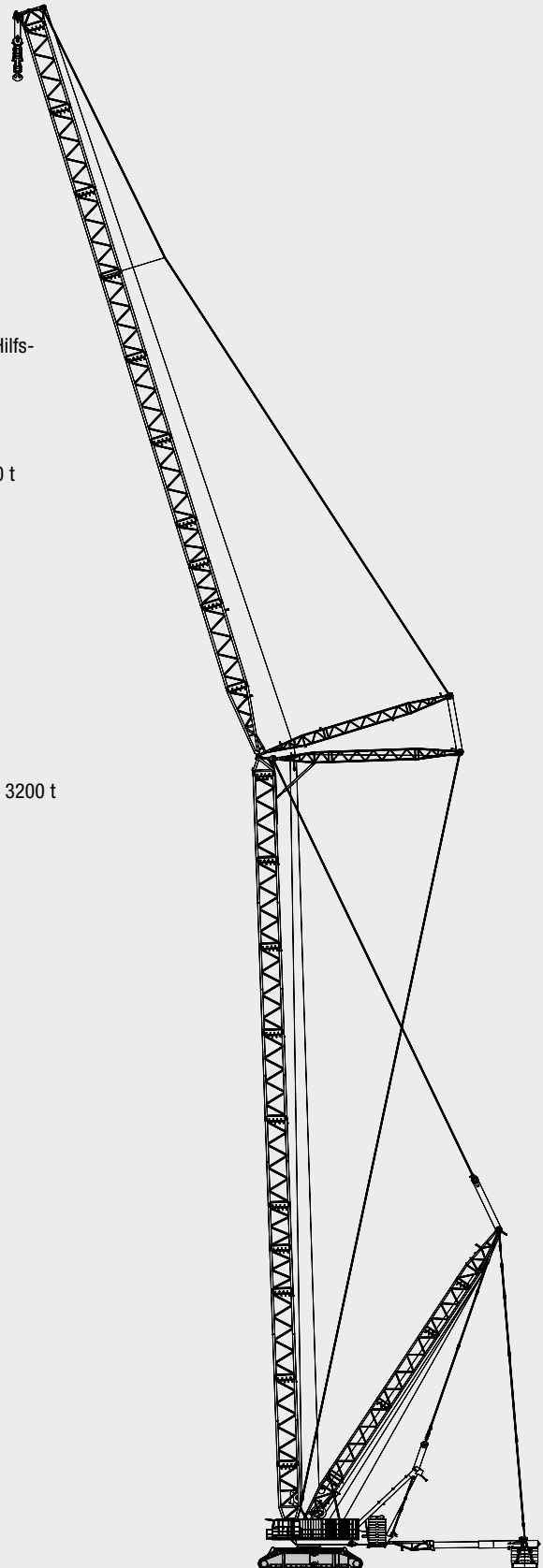

CONTENTS · INHALT · CONTENU

Page · Seite · Page:

Specifications · Technische Daten · Caractéristiques

Specifications · Technische Daten · Caractéristiques	4
Superlift configurations · Superlift-Konfigurationen · Combinaisons Superlift	7
Specifications · Technische Daten · Caractéristiques	8
Boom combinations · Ausleger-Kombinationen · Combinaisons de flèche	10

1

Main boom · Hauptausleger · Flèche principale

Working ranges with Superlift · Arbeitsbereiche mit Superlift · Portées avec Superlift (SSL, HSSL, SSL/LSL)	12
Lifting capacities with Superlift · Tragfähigkeiten mit Superlift · Capacités de levage avec Superlift (SSL, HSSL, SSL/LSL)	13

2

Luffing fly jib · Wippbarer Hilfsausleger · Fléchette à volée variable

Working ranges with SL · Arbeitsbereiche mit SL · Portées avec SL (SWSL)	16
Lifting capacities with Superlift · Tragfähigkeiten mit Superlift · Capacités de levage avec Superlift (SWSL / SFSL 15°)	17

3

Fixed fly jib · Starrer Hilfsausleger · Fléchette fixe

Working ranges with SL · Arbeitsbereiche mit SL · Portées avec SL (SFVL)	50
Lifting capacities with SL · Tragfähigkeiten mit SL · Capacités de levage avec SL (SFVL)	51

4

Technical description · Technische Beschreibung · Descriptif technique

Crawler carrier · Superstructure · Optional equipment	52
Boom configurations · Optional equipment	53
Raupenunterwagen · Oberwagen · Zusatzausrüstung	54
Auslegervarianten · Zusatzausrüstung	55
Châssis à chenilles · Partie supérieure · Equipements optionnels	56
Combinaisons de flèche · Equipements optionnels	57

5

SPECIFICATIONS · TECHNISCHE DATEN · CARACTÉRISTIQUES
WORKING SPEEDS (INFINITELY VARIABLE) · ARBEITSGESCHWINDIGKEITEN (STUFENLOS REGELBAR) · VITESSES DE TRAVAIL (RÉGLABLES SANS PALIERS)

Mechanisms Antriebe Mécanismes	Rope \varnothing Seil- \varnothing \varnothing du câble	Speeds ¹⁾ Geschwindigkeiten ¹⁾ Vitesses ¹⁾	Single line pull ²⁾ Seilzug je Strang ²⁾ Effort sur brin simple ²⁾	Length of hoist rope Länge des Hubseils Longueur du câble de levage
Hoist I+II (H1+H2) Hubwerk I+II (H1+H2) Treuil de levage I+II (H1+H2)	40 mm	max. 120 m / min	352 kN	1540 m
Runner winch R (H3) – option Runnerwinde R (H3) – Option Tambour potence R (H3) – option	40 mm	max. 90 m / min	352 kN	700 m
Boom derricking (W2) Wippwerk Hauptausleger (W2) Variation de flèche (W2)	40 mm	max. 120 m / min		
Boom hoist (E) Einziehwerk (E) Relevage de flèche (E)	40 mm	max. 40 m / min		
Jib luffing (W1) Wippwerk Hilfsausleger (W1) Variation de volée (W1)	40 mm	max. 105 m / min		
Slewing (rpm) Drehwerk (U/min) Orientation (tr/mn)		0 – 0,6 ¹⁾ /min		

1) top layers · oberste Lagen · couches supérieures

2) with reeving effect considered · Angabe mit Wirkungsgrad der Einscherung · tenant compte de l'effort de mouflage

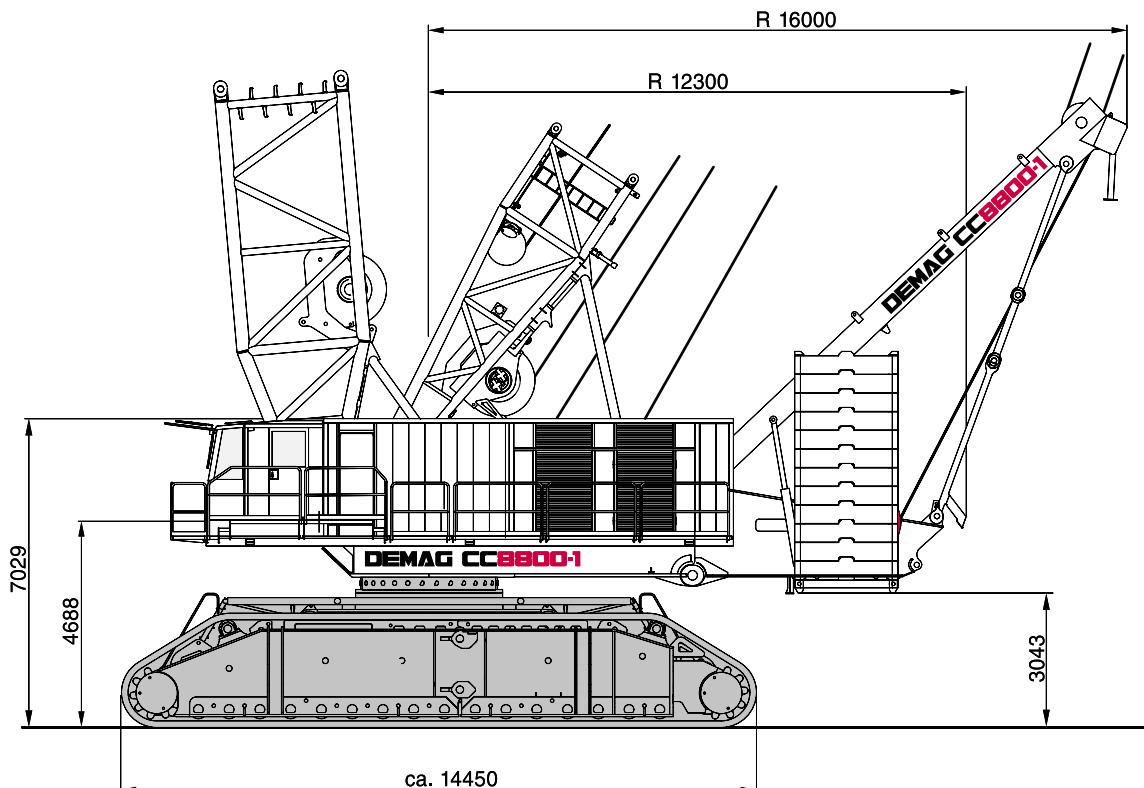

SPECIFICATIONS · TECHNISCHE DATEN · CARACTÉRISTIQUES

CARRIER PERFORMANCE · FAHRLEISTUNGEN · PERFORMANCES DU PORTEUR

1 st gear · 1. Gang · 1 ^{ère} vitesse	max. 0,4 km/h
2 nd gear · 2. Gang · 2 ^{ème} vitesse	max. 0,8 km/h

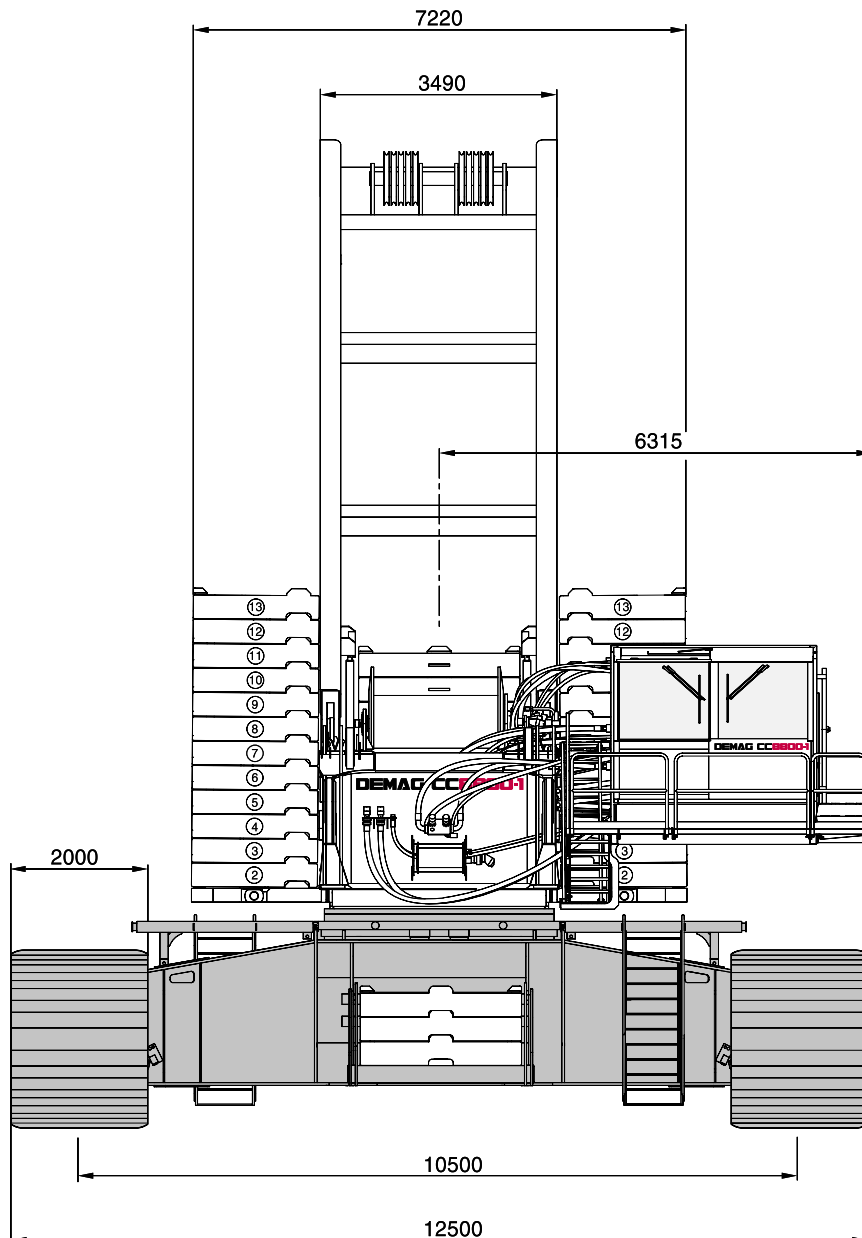

SPECIFICATIONS · TECHNISCHE DATEN · CARACTÉRISTIQUES
HOOK BLOCK SYSTEM · UNTERFLASCHENSYSTEM · SYSTÈME DE CROCHET-MOUFLE

Type Typ Type	Possible load Mögliche Traglast Charge possible	Number of sheaves Anzahl der Rollen Nombre de poulies	Number of lines Strangzahl Nombre de brins	Weight Gewicht Poids	„D“
2 x 800	1600 t	2 x 13	2 x 26	44 000 kg	8,70 m
	800 t	2 x 7	2 x 12	28 000 kg	6,50 m
	800 t	1 x 13	2 x 12	28 000 kg	6,20 m
	495 t	1 x 7	1 x 14	22 000 kg	6,50 m
2 x 675	1350 t	2 x 10	2 x 21	39 000 kg / 21 000 kg	8,50 m
	675 t	2 x 5	2 x 11	16 000 kg / 12 500 kg	6,00 m
	675 t	1 x 10	1 x 21	16 000 kg / 12 500 kg	6,00 m
	370 t	1 x 5	1 x 11	14 500 kg / 8 000 kg	6,00 m
100	100 t	1 x 1	1 x 3	7 700 kg / 3 700 kg	4,50 m

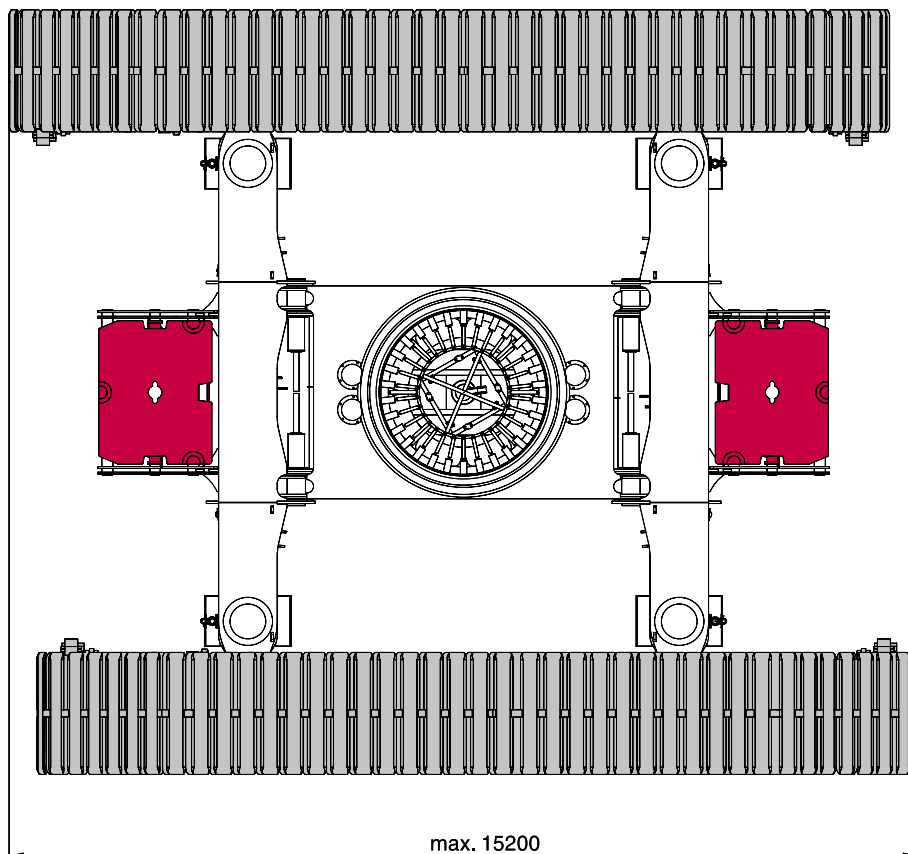

**SUPERLIFT CONFIGURATIONS · SUPERLIFT-KONFIGURATIONEN ·
COMBINAISONS SUPERLIFT**

**STANDARD SUPERLIFT ATTACHMENT · SERIENMÄßIGE SUPERLIFTEINRICHTUNG ·
SUPERLIFT DE SÉRIE**

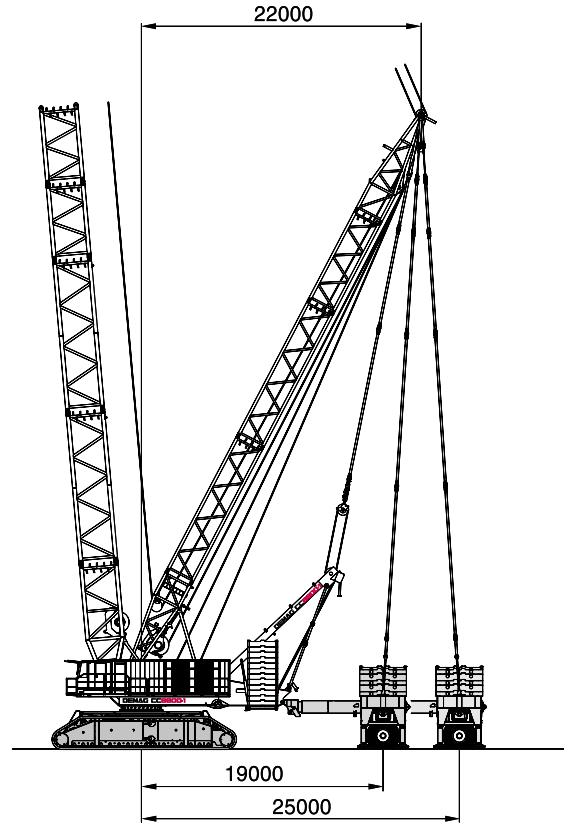
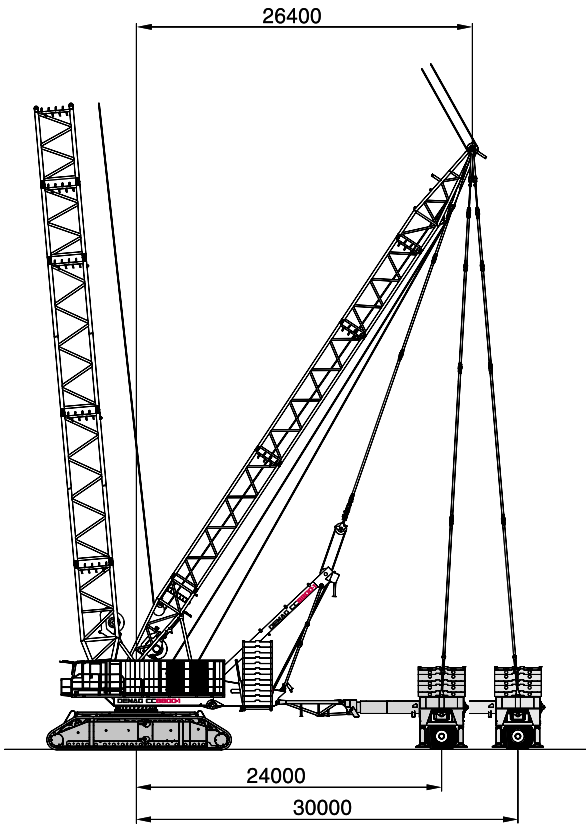

VARIABLE SUPERLIFT ATTACHMENT · VARIABLE SUPERLIFTEINRICHTUNG · SUPERLIFT VARIABLE

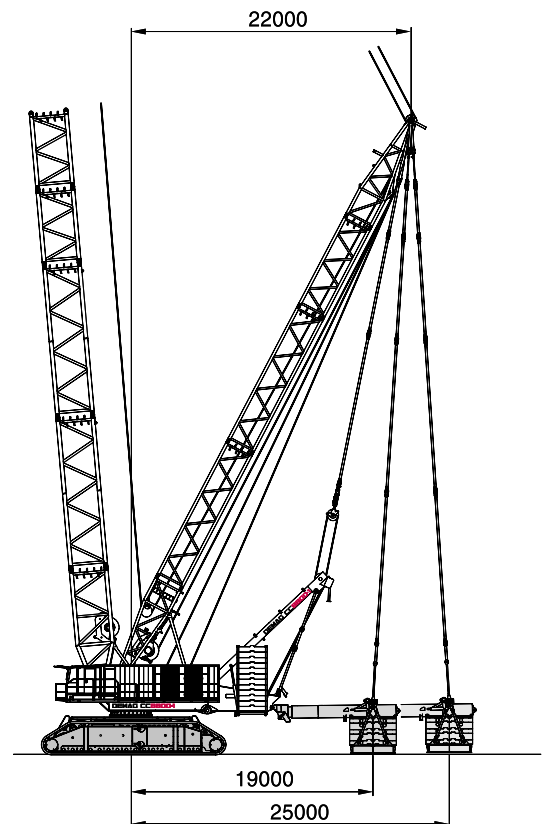
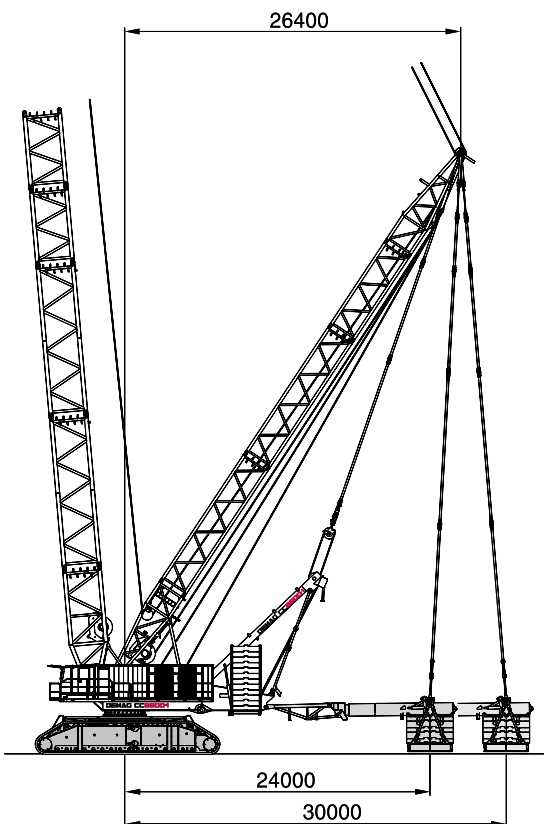

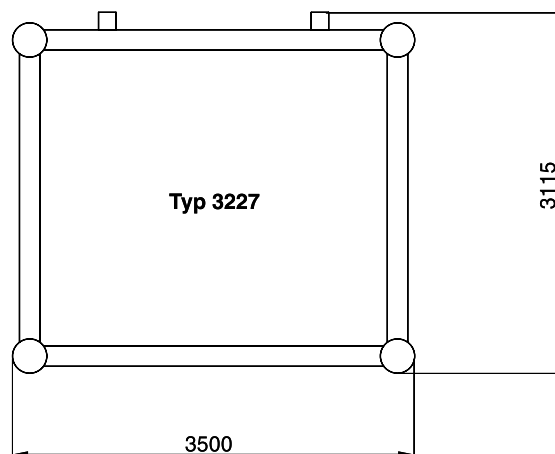
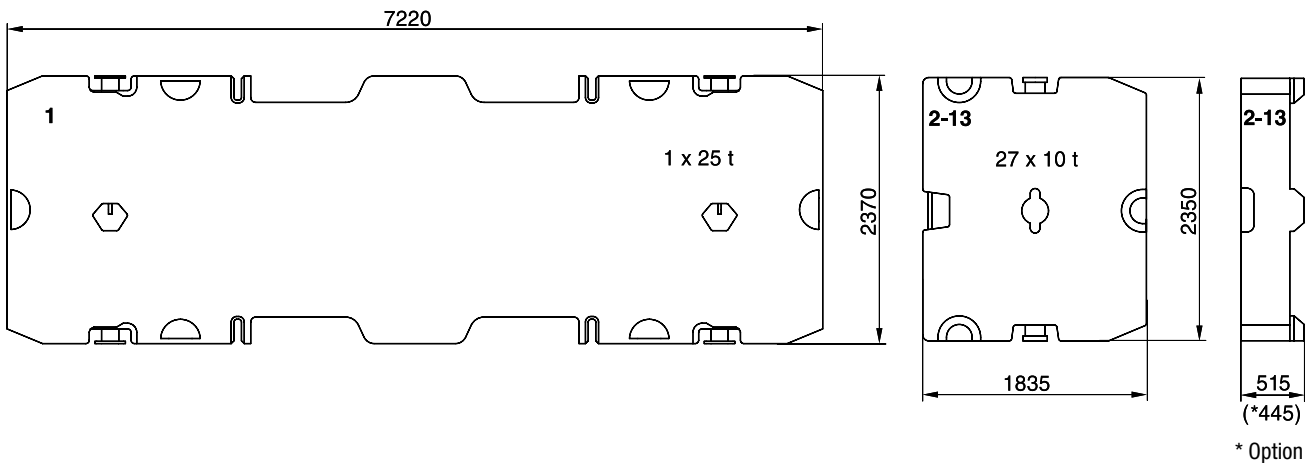
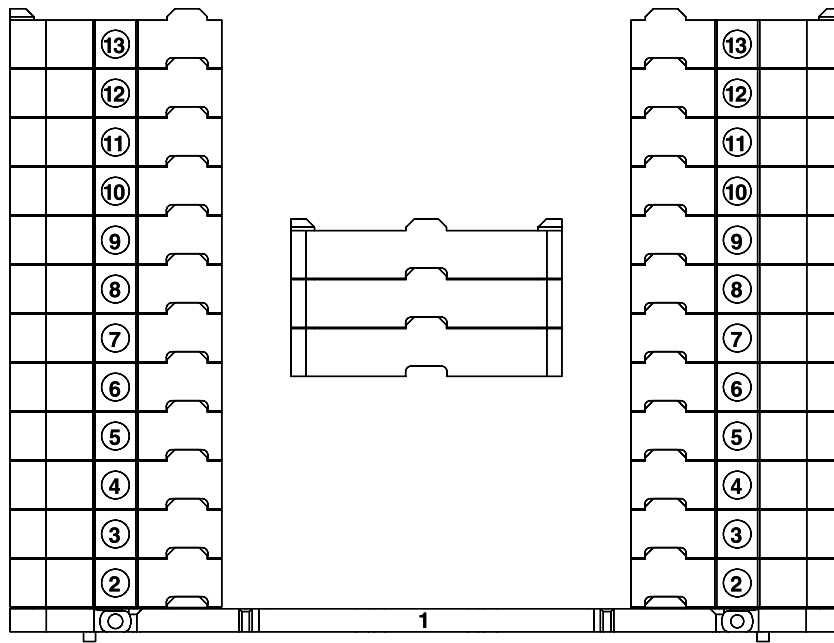
SPECIFICATIONS · TECHNISCHE DATEN · CARACTÉRISTIQUES

SPECIFICATIONS · TECHNISCHE DATEN · CARACTÉRISTIQUES

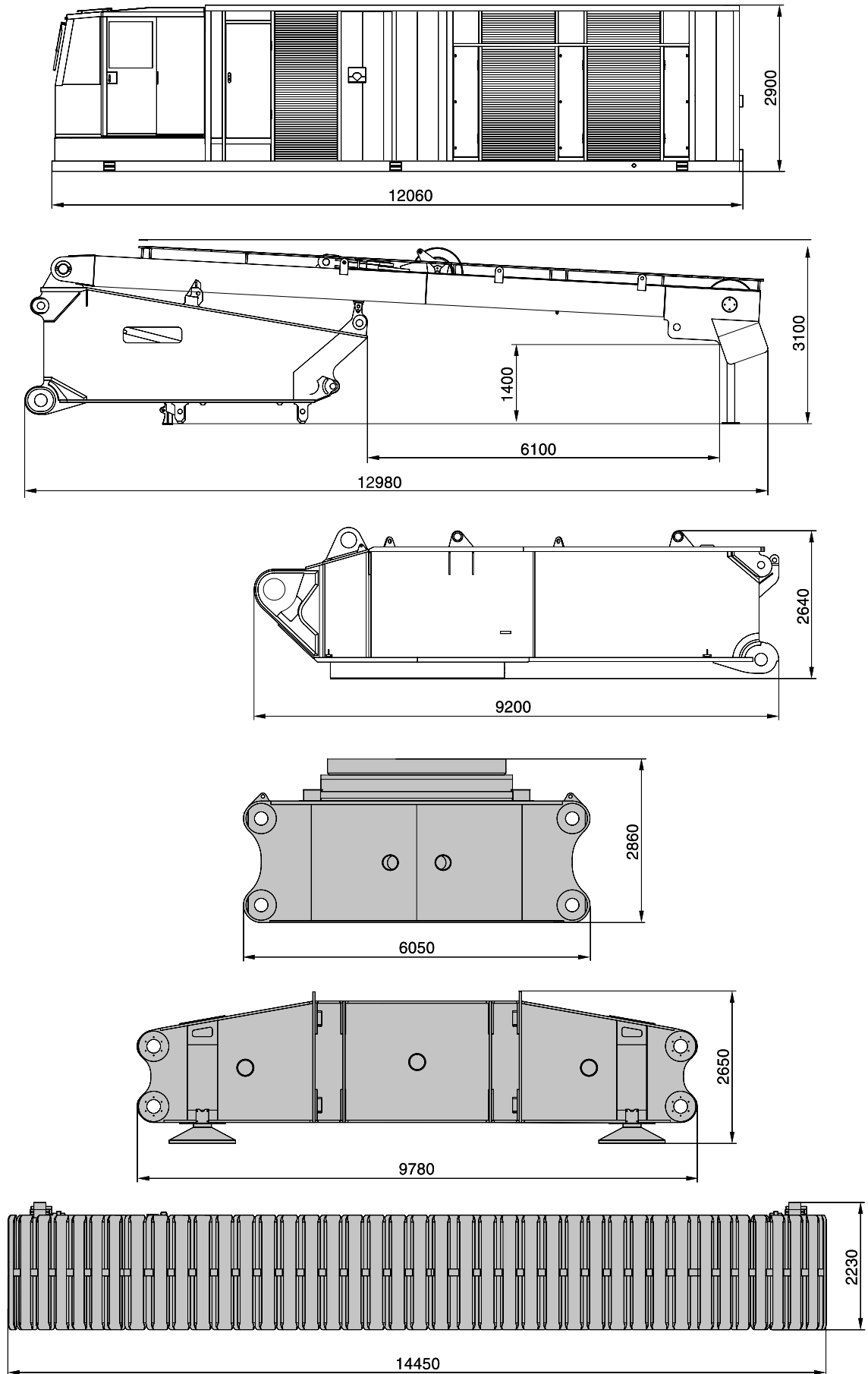

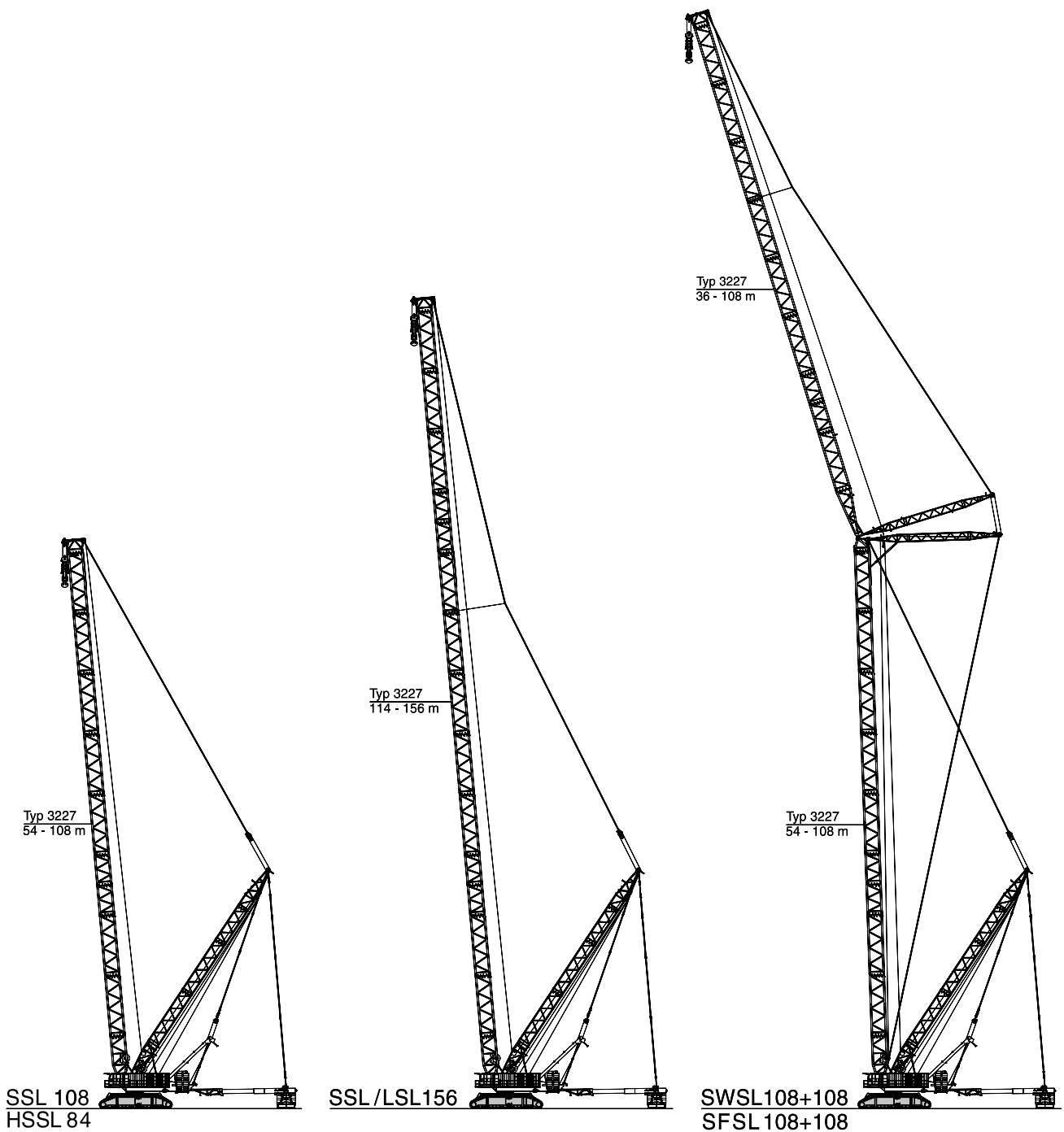

BOOM COMBINATIONS · AUSLEGER-KOMBINATIONEN · COMBINAISONS DE FLÈCHE

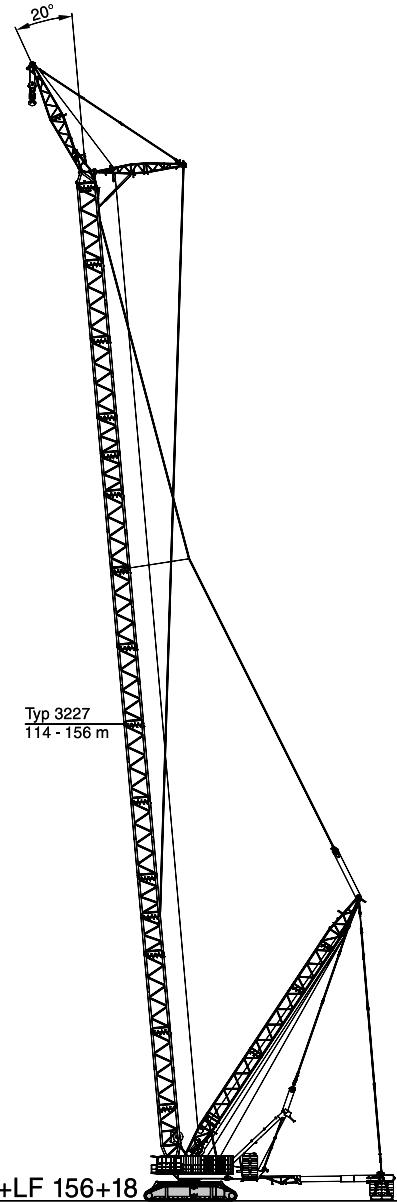
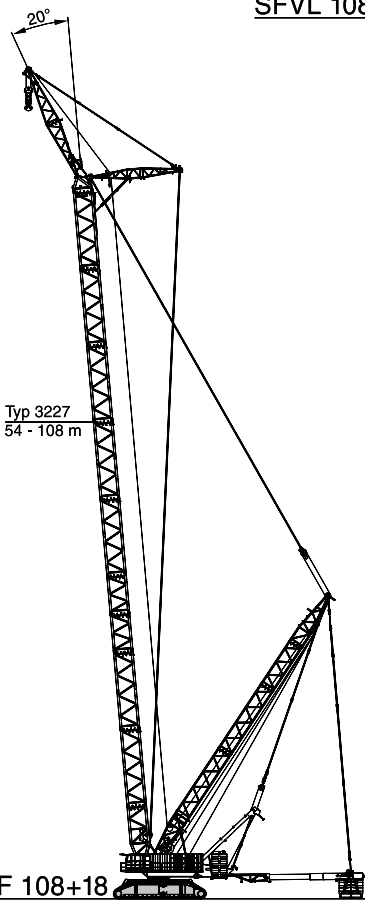
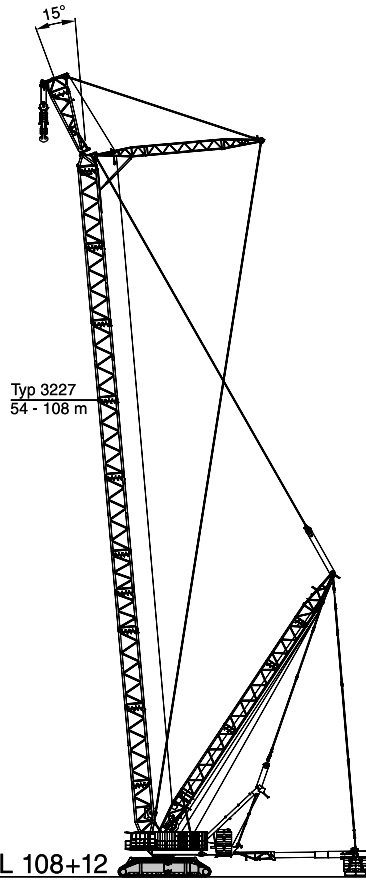

SSL, HSSL, SSL/LSL WORKING RANGES · ARBEITSBEREICHE · PORTÉES

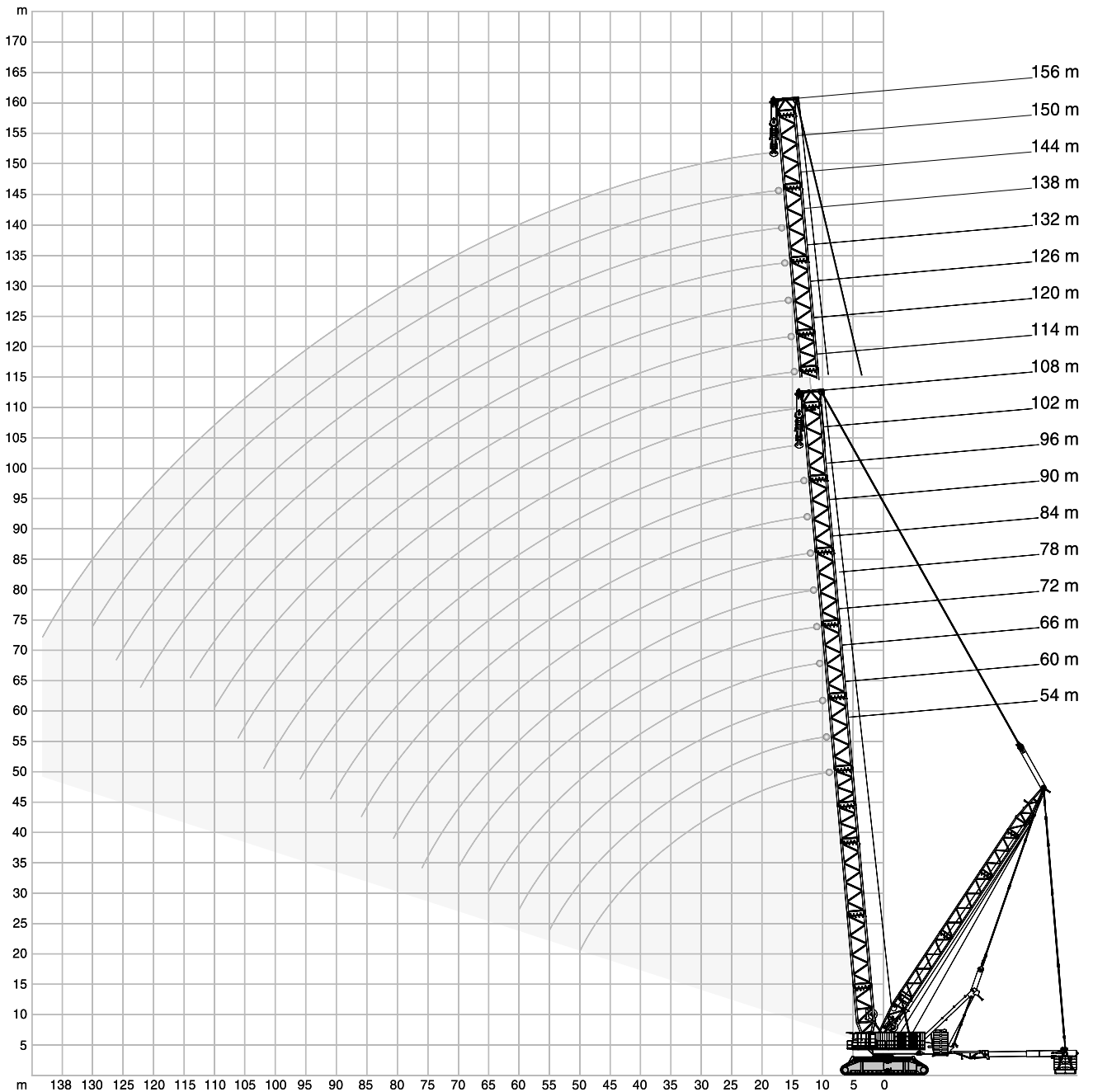

SSL, HSSL LIFTING CAPACITIES · TRAGFÄHIGKEITEN ·
CAPACITÉS DE LEVAGE

295 t + 60 t ZB		19-30 m		10,50 m		360°		DIN/ISO			
48 m		54 m		60 m		66 m		72 m		78 m	
0t-640t		0t-640t		0t		0t-640t		0t		0t-640t	
m	t	t	t	t	t	t	t	t	t	t	m
10	1600,0	1600,0	799,0	1555,0	-	-	-	-	-	-	10
11	1600,0	1581,0	726,5	1553,0	684,0	1405,0	651,0	1238,0	-	-	11
12	1565,0	1562,0	654,0	1553,0	623,0	1405,0	594,0	1238,0	568,0	1098,0	12
14	1490,0	1487,0	551,0	1478,0	527,0	1383,0	505,0	1238,0	484,0	1098,0	14
16	1421,0	1419,0	474,0	1410,0	455,0	1383,0	436,0	1238,0	419,0	1098,0	16
18	1309,0	1309,0	414,0	1302,0	398,0	1290,0	383,0	1204,0	368,0	1098,0	18
20	1192,0	1192,0	367,0	1185,0	353,0	1178,0	339,0	1168,0	326,0	1060,0	20
22	1091,0	1085,0	323,0	1079,0	315,0	1073,0	303,0	1069,0	292,0	1038,0	22
24	992,0	992,0	282,0	986,0	278,0	980,0	273,0	976,0	263,0	973,0	24
26	909,0	913,0	249,0	907,0	245,0	901,0	242,0	897,0	239,0	893,0	26
28	827,0	845,0	222,0	839,0	218,0	833,0	215,0	829,0	213,0	825,0	28
30	748,0	785,0	199,0	779,0	195,0	774,0	192,0	770,0	190,0	766,0	30
34	617,0	687,0	163,0	682,0	159,0	676,0	156,0	672,0	154,0	668,0	34
38	513,0	580,0	136,0	604,0	132,0	599,0	129,0	594,0	126,0	591,0	38
42	424,0	491,0	116,0	532,0	111,0	536,0	108,0	532,0	104,0	528,0	42
46	-	436,0	99,5	457,0	94,0	484,0	90,0	479,0	87,0	476,0	46
50	-	367,0	86,0	392,0	80,0	424,0	76,0	435,0	72,0	431,0	50
54	-	-	75,0	353,0	68,5	369,0	64,0	394,0	60,5	393,0	54
55	-	-	73,0	339,0	66,2	356,2	61,6	382,0	58,0	385,0	55
58	-	-	-	-	59,5	324,0	54,5	346,0	50,5	361,0	58
60	-	-	-	-	55,5	312,0	50,6	324,0	46,4	342,5	60
62	-	-	-	-	-	-	46,8	302,0	42,3	324,0	62
65	-	-	-	-	-	-	41,9	278,0	37,1	294,7	65
66	-	-	-	-	-	-	-	-	35,4	285,0	66
70	-	-	-	-	-	-	-	-	29,8	249,0	70

84 m		90 m		96 m		102 m		108 m			
0t		0t-640t		0t		0t-640t		0t		0t-640t	
m	t	t	t	t	t	t	t	t	t	t	m
12	543,0	976,0	-	-	-	-	-	-	-	-	12
13	503,0	976,0	479,0	867,0	459,0	775,0	-	-	-	-	13
14	463,0	976,0	445,0	867,0	426,0	775,0	409,0	695,0	392,0	625,0	14
16	402,0	976,0	387,0	867,0	371,0	775,0	357,0	695,0	342,0	625,0	16
18	353,0	976,0	340,0	867,0	327,0	775,0	314,0	695,0	302,0	625,0	18
20	314,0	973,0	302,0	867,0	290,0	775,0	279,0	695,0	268,0	625,0	20
22	281,0	940,0	270,0	858,0	260,0	774,0	250,0	695,0	240,0	625,0	22
24	253,0	927,0	244,0	846,0	234,0	766,0	225,0	692,0	215,0	624,0	24
26	229,0	888,0	220,0	829,0	212,0	759,0	203,0	687,0	194,0	621,0	26
28	208,0	820,0	200,0	818,0	192,0	747,0	184,0	683,0	176,0	617,0	28
30	187,0	761,0	183,0	759,0	175,0	743,0	168,0	674,0	160,0	613,0	30
34	150,0	663,0	149,0	661,0	146,0	657,0	140,0	653,0	133,0	600,0	34
38	123,0	586,0	121,0	583,0	118,0	579,0	115,0	576,0	111,0	569,0	38
42	100,0	523,0	98,5	521,0	95,0	516,0	92,0	513,0	90,0	510,0	42
46	82,5	471,0	80,5	468,0	77,0	464,0	73,5	461,0	71,5	458,0	46
50	68,0	426,0	65,5	423,0	62,0	419,0	58,5	416,0	56,5	413,0	50
54	55,5	388,0	53,5	385,0	49,7	381,0	46,5	378,0	44,3	375,0	54
58	45,8	355,0	43,2	353,0	39,4	348,0	36,1	345,0	33,8	342,0	58
62	37,3	327,0	34,6	324,0	30,6	320,0	27,2	316,0	24,8	314,0	62
66	30,2	301,0	27,2	300,0	23,1	295,0	19,6	292,0	17,0	289,0	66
70	24,2	267,0	20,9	278,0	16,6	274,0	13,0	270,0	10,3	267,0	70
72	21,7	251,5	18,2	265,0	13,8	264,0	10,1	260,0	-	257,0	72
74	19,2	236,0	15,5	252,0	11,1	254,0	-	250,0	-	247,0	74
76	17,0	220,0	13,2	238,0	-	244,0	-	241,5	-	238,5	76
78	-	-	11,0	224,0	-	234,0	-	233,0	-	230,0	78
79	-	-	10,0	217,0	-	227,7	-	229,2	-	226,0	79
81	-	-	-	203,0	-	215,2	-	221,7	-	218,0	81
82	-	-	-	-	-	209,0	-	218,0	-	214,0	82
86	-	-	-	-	-	185,0	-	196,0	-	200,0	86
90	-	-	-	-	-	-	-	175,0	-	183,0	90
91	-	-	-	-	-	-	-	169,0	-	178,2	91
94	-	-	-	-	-	-	-	-	-	164,0	94
96	-	-	-	-	-	-	-	-	-	154,0	96

SSL/LSL LIFTING CAPACITIES · TRAGFÄHIGKEITEN · CAPACITÉS DE LEVAGE

295 t + 60 t ZB		19-30 m		10,50 m		360°		DIN/ISO			
m	114 m		120 m		126 m		132 m		138 m		m
	0 t	0t-640t	0 t	0t-640t	0 t	0t-640t	0 t	0t-640t	0 t	0t-640t	
16	333,0	562,0	321,0	506,0	311,0	457,0	300,0	410,0	-	-	16
18	295,0	562,0	284,0	506,0	276,0	457,0	266,0	410,0	258,0	369,0	18
20	263,0	562,0	252,0	506,0	246,0	457,0	237,0	410,0	230,0	369,0	20
22	235,0	562,0	226,0	506,0	220,0	456,0	212,0	410,0	206,0	369,0	22
24	212,0	562,0	203,0	506,0	198,0	456,0	191,0	410,0	185,0	369,0	24
26	191,0	561,0	184,0	506,0	179,0	456,0	173,0	410,0	167,0	369,0	26
28	174,0	559,0	166,0	504,0	162,0	453,0	156,0	410,0	151,0	369,0	28
30	158,0	556,0	151,0	501,0	147,0	447,0	142,0	410,0	137,0	369,0	30
34	131,0	552,0	125,0	495,0	122,0	435,0	117,0	409,0	113,0	368,0	34
38	110,0	529,0	104,0	489,0	102,0	423,0	97,5	408,0	94,0	367,0	38
42	91,0	504,0	87,0	458,0	85,0	405,0	80,5	403,0	77,5	366,0	42
46	72,5	459,0	70,5	438,0	70,5	388,0	66,5	388,0	63,5	355,0	46
50	57,5	415,0	55,0	412,0	56,0	370,0	54,5	365,0	52,0	344,0	50
54	45,2	376,0	42,8	374,0	43,5	352,0	42,4	352,0	40,8	323,0	54
58	34,6	343,0	32,1	341,0	32,8	334,0	31,7	339,0	30,0	313,0	58
62	25,6	315,0	23,0	312,0	23,7	312,0	22,5	311,0	20,8	303,0	62
66	17,8	290,0	15,2	287,0	15,8	287,0	14,6	286,0	12,8	284,0	66
70	11,1	268,0	-	265,0	-	265,0	-	264,0	-	262,0	70
74	-	248,0	-	245,0	-	245,0	-	244,0	-	242,0	74
78	-	231,0	-	228,0	-	228,0	-	226,0	-	224,0	78
82	-	215,0	-	212,0	-	212,0	-	210,0	-	208,0	82
86	-	201,0	-	198,0	-	198,0	-	196,0	-	194,0	86
90	-	188,0	-	185,0	-	185,0	-	183,0	-	181,0	90
94	-	175,0	-	173,0	-	173,0	-	171,0	-	169,0	94
98	-	158,0	-	163,0	-	162,0	-	160,0	-	158,0	98
102	-	141,0	-	147,0	-	153,0	-	151,0	-	148,0	102
106	-	-	-	132,0	-	140,0	-	141,0	-	139,0	106
110	-	-	-	-	-	126,0	-	131,0	-	131,0	110
114	-	-	-	-	-	-	-	119,0	-	122,0	114
118	-	-	-	-	-	-	-	-	-	111,0	118
122	-	-	-	-	-	-	-	-	-	99,5	122

SSL/LSL LIFTING CAPACITIES · TRAGFÄHIGKEITEN · CAPACITÉS DE LEVAGE

295 t + 60 t ZB		19-30 m		10,50 m		360°		DIN/ISO	
144 m		150 m		156 m					
0 t		0t-640t		0 t		0t-640t		0 t	
0t-640t		0t-640t		0t-640t		0t-640t		0t-640t	
m	t	t	t	t	t	t	t	m	t
18	248,0	331,0	243,0	299,0	234,0	268,0		18	
20	221,0	331,0	217,0	299,0	209,0	268,0		20	
22	198,0	331,0	195,0	299,0	187,0	268,0		22	
24	179,0	331,0	175,0	299,0	169,0	268,0		24	
26	161,0	331,0	158,0	299,0	152,0	267,0		26	
28	145,0	331,0	143,0	299,0	137,0	267,0		28	
30	132,0	331,0	130,0	299,0	124,0	267,0		30	
34	108,0	331,0	107,0	298,0	102,0	265,0		34	
38	89,0	330,0	88,5	296,0	83,5	262,0		38	
42	73,0	329,0	72,5	294,0	68,0	259,0		42	
46	59,5	323,0	59,0	291,0	55,0	256,0		46	
50	48,0	313,0	47,9	283,0	44,0	251,0		50	
54	37,8	304,0	38,0	276,0	34,1	246,0		54	
58	29,0	290,0	29,2	269,0	25,4	240,0		58	
62	19,7	279,0	20,5	262,0	17,8	235,0		62	
66	11,7	270,0	12,5	250,0	11,0	229,0		66	
70	-	260,0	-	244,0	-	221,0		70	
74	-	240,0	-	237,0	-	215,0		74	
78	-	223,0	-	223,0	-	210,0		78	
82	-	207,0	-	207,0	-	205,0		82	
86	-	193,0	-	193,0	-	192,0		86	
90	-	179,0	-	180,0	-	179,0		90	
94	-	168,0	-	168,0	-	167,0		94	
98	-	157,0	-	157,0	-	156,0		98	
102	-	147,0	-	147,0	-	146,0		102	
106	-	137,0	-	138,0	-	136,0		106	
110	-	129,0	-	129,0	-	128,0		110	
114	-	121,0	-	122,0	-	120,0		114	
118	-	114,0	-	114,0	-	112,0		118	
122	-	103,0	-	108,0	-	106,0		122	
126	-	93,0	-	98,0	-	99,5		126	
130	-	-	-	88,5	-	90,5		130	
134	-	-	-	-	-	81,5		134	
138	-	-	-	-	-	72,5		138	
142	-	-	-	-	-	-		142	

SWSL WORKING RANGES · ARBEITSBEREICHE · PORTÉES

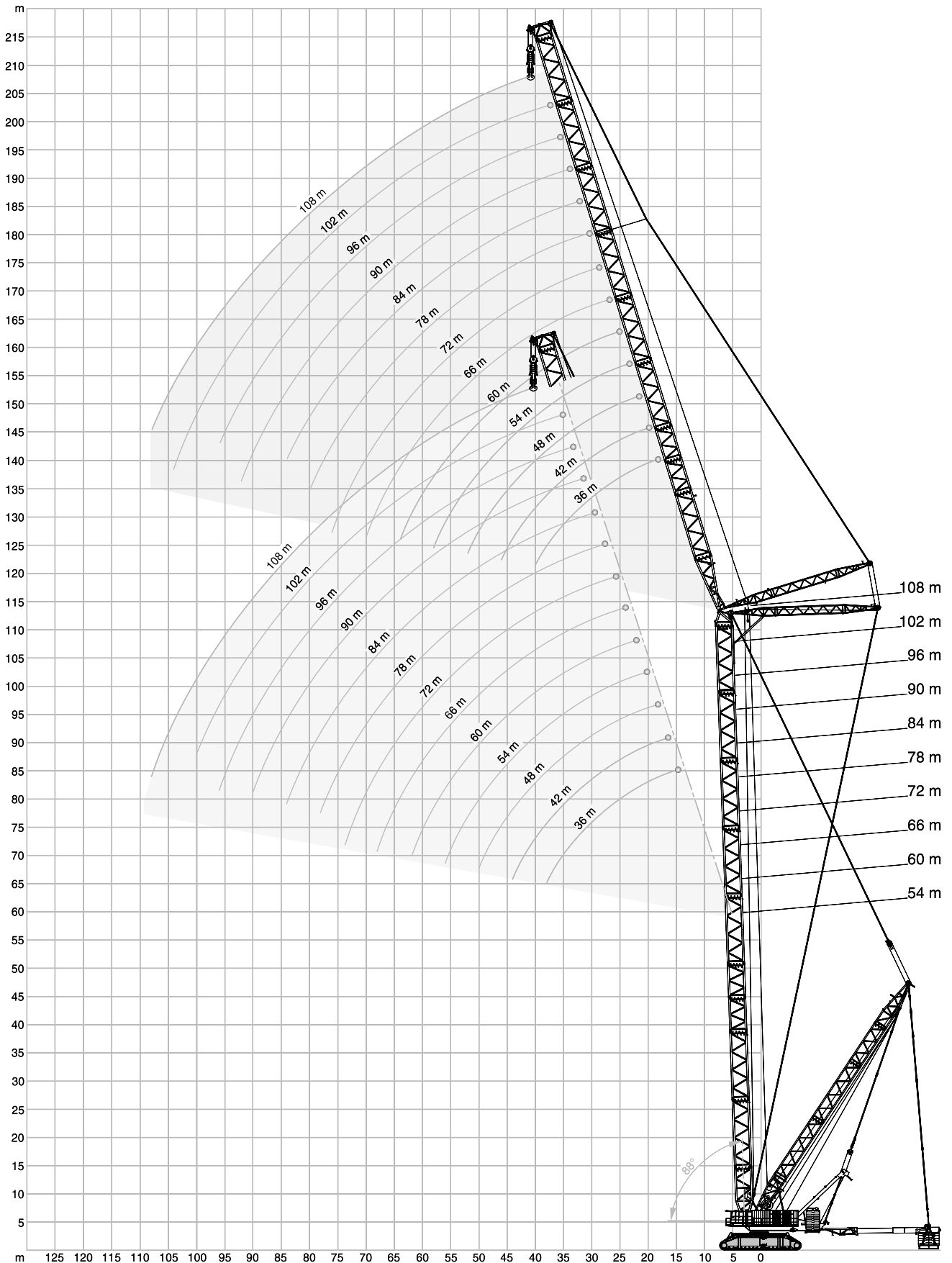

SWSL / SFSL 15° LIFTING CAPACITIES · TRAGFÄHIGKEITEN · CAPACITÉS DE LEVAGE

295 t + 60 t ZB
19-30 m
10,50 m
360°
DIN/ISO

54 m + 36 m

m	SWSL						SFSL
	0 t		0 t - 640 t				t
	85°	85°	75°	65°	55°	45°	
18	-	629,0*	-	-	-	-	-
20	-	614,0*	-	-	-	-	-
22	-	594,0*	-	-	-	-	-
24	291,0	653,0	-	-	-	-	640,0
26	268,0	639,0	-	-	-	-	640,0
28	249,0	603,0	-	-	-	-	640,0
30	231,0	543,0	-	-	-	-	640,0
34	197,0	450,0	-	-	-	-	632,0
37	175,5	398,5	613,0	-	-	-	611,5
38	169,0	383,0	582,0	-	-	-	598,0
42	146,0	332,0	478,0	-	-	-	532,0
46	-	-	403,0	-	-	-	477,0
50	-	-	348,0	-	-	-	431,0
51	-	-	336,5	424,0	-	-	420,5
52	-	-	325,0	414,0	-	-	410,0
54	-	-	-	397,0	-	-	389,0
58	-	-	-	360,0	-	-	345,0
61	-	-	-	325,0	-	-	315,7
62	-	-	-	-	-	-	306,0
64	-	-	-	-	291,0	-	288,5
66	-	-	-	-	280,0	-	271,0
69	-	-	-	-	265,0	-	247,7
70	-	-	-	-	-	-	240,0
74	-	-	-	-	-	222,0	220,0
76	-	-	-	-	-	215,0	208,0
78	-	-	-	-	-	-	196,0
82	-	-	-	-	-	-	170,0

54 m + 48 m

m	t	t	t	t	t	t	t
22	-	496,0*	-	-	-	-	-
24	-	484,0*	-	-	-	-	-
26	-	471,0*	-	-	-	-	-
28	233,0	516,0	-	-	-	-	504,0
30	217,0	508,0	-	-	-	-	504,0
34	190,0	484,0	-	-	-	-	504,0
38	165,0	411,0	-	-	-	-	504,0
42	143,0	356,0	-	-	-	-	496,0
43	138,5	344,5	490,0	-	-	-	488,0
46	125,0	313,0	434,0	-	-	-	463,0
50	111,0	278,0	373,0	-	-	-	431,0
54	99,0	244,0	326,0	-	-	-	393,0
58	-	-	289,0	-	-	-	358,0
59	-	-	281,0	354,0	-	-	349,5
62	-	-	259,0	333,0	-	-	324,0
66	-	-	-	297,0	-	-	291,0
70	-	-	-	265,0	-	-	260,0
72	-	-	-	252,0	-	-	246,5
73	-	-	-	-	241,0	-	239,7
74	-	-	-	-	237,0	-	233,0
78	-	-	-	-	222,0	-	208,0
80	-	-	-	-	215,0	-	197,5
82	-	-	-	-	-	-	190,0
85	-	-	-	-	-	181,0	177,2
86	-	-	-	-	-	178,0	173,0
87	-	-	-	-	-	176,0	167,7
90	-	-	-	-	-	-	152,0
94	-	-	-	-	-	-	132,0
98	-	-	-	-	-	-	-

54 m + 60 m

m	SWSL						SFSL
	0 t		0 t - 640 t				t
	85°	85°	75°	65°	55°	45°	
26	-	394,0*	-	-	-	-	-
28	-	386,0*	-	-	-	-	-
30	-	378,0*	-	-	-	-	-
32	191,0	411,0	-	-	-	-	401,0
34	179,0	406,0	-	-	-	-	401,0
38	158,0	396,0	-	-	-	-	401,0
42	141,0	367,0	-	-	-	-	401,0
46	124,0	322,0	-	-	-	-	401,0
49	113,5	293,5	400,0	-	-	-	391,0
50	110,0	285,0	385,0	-	-	-	387,0
54	97,5	255,0	336,0	-	-	-	363,0
58	87,5	229,0	297,0	-	-	-	340,0
62	78,5	208,0	264,0	-	-	-	319,0
64	75,0	197,0	250,0	-	-	-	310,0
66	-	-	238,0	-	-	-	301,0
67	-	-	232,0	296,0	-	-	295,2
70	-	-	215,0	271,0	-	-	278,0
74	-	-	195,0	243,0	-	-	251,0
78	-	-	-	220,0	-	-	227,0
82	-	-	-	200,0	205,0	-	204,0
86	-	-	-	-	193,0	-	184,0
90	-	-	-	-	182,0	-	167,0
92	-	-	-	-	176,0	-	161,0
94	-	-	-	-	-	-	155,0
95	-	-	-	-	-	153,0	150,7
98	-	-	-	-	-	146,0	138,0
99	-	-	-	-	-	144,0	134,0
102	-	-	-	-	-	-	122,0
106	-	-	-	-	-	-	105,0

54 m + 72 m

m	t	t	t	t	t	t	t
30	-	315,0*	-	-	-	-	-
34	-	306,0*	-	-	-	-	-
36	157,0	328,0	-	-	-	-	321,0
38	148,0	325,0	-	-	-	-	321,0
42	132,0	320,0	-	-	-	-	321,0
46	118,0	314,0	-	-	-	-	321,0
50	106,0	283,0	-	-	-	-	321,0
54	95,0	253,0	-	-	-	-	315,0
56	89,5	240,0	314,0	-	-	-	309,5
58	84,5	227,0	295,0	-	-	-	304,0
62	75,5	206,0	263,0	-	-	-	286,0
66	68,0	187,0	236,0	-	-	-	269,0
70	61,0	171,0	213,0	-	-	-	253,0
74	55,0	157,0	193,0	241,0	-	-	239,0
76	52,0	146,0	185,0	229,0	-	-	233,0
78	-	-	176,0	218,0	-	-	227,0
82	-	-	162,0	198,0	-	-	215,0
86	-	-	149,0	180,0	-	-	196,0
90	-	-	-	165,0	-	-	178,0
91	-	-	-	161,5	174,0	-	173,5
94	-	-	-	152,0	166,0	-	160,0
98	-	-	-	-	157,0	-	145,0
102	-	-	-	-	148,0	-	136,0
105	-	-	-	-	-	127,0	126,2
106	-	-	-	-	-	125,0	123,0
110	-	-	-	-	-	118,0	109,0
114	-	-	-	-	-	-	95,5

Remarks · Bemerkungen · Remarques: * Main boom angle 88° · Hauptauslegerwinkel 88° · Jarret de flèche principale 88°
 see page 18 · siehe Seite 18 · voir page 18

SWSL / SFSL15° LIFTING CAPACITIES · TRAGFÄHIGKEITEN · CAPACITÉS DE LEVAGE

295 t + 60 t ZB
19-30 m
10,50 m
360°
DIN/ISO

54 m + 84 m

54 m + 96 m

m	SWSL							SFSL
	0 t		0 t - 640 t					
	85°	85°	75°	65°	55°	45°	t	
32	-	254,0*	-	-	-	-	-	
34	-	253,0*	-	-	-	-	-	
38	-	247,0*	-	-	-	-	-	
40	128,0	261,0	-	-	-	-	258,0	
42	120,0	260,0	-	-	-	-	258,0	
46	107,0	256,0	-	-	-	-	258,0	
50	96,0	252,0	-	-	-	-	258,0	
54	86,0	247,0	-	-	-	-	258,0	
58	77,5	221,0	-	-	-	-	256,0	
62	69,5	199,0	254,0	-	-	-	248,0	
66	61,0	181,0	229,0	-	-	-	240,0	
70	54,0	165,0	207,0	-	-	-	226,0	
74	48,1	151,0	187,0	-	-	-	212,0	
78	42,6	138,0	170,0	-	-	-	200,0	
82	37,8	127,0	155,0	191,0	-	-	190,0	
86	33,6	115,5	142,0	174,0	-	-	180,0	
88	31,7	109,0	136,0	166,0	-	-	175,5	
90	-	-	131,0	159,0	-	-	171,0	
94	-	-	121,0	145,0	-	-	162,0	
96	-	-	116,0	139,0	-	-	156,0	
98	-	-	-	134,0	-	-	150,0	
100	-	-	-	128,0	143,0	-	143,0	
102	-	-	-	123,0	139,0	-	136,0	
106	-	-	-	114,0	131,0	-	123,0	
110	-	-	-	-	124,0	-	115,0	
114	-	-	-	-	114,0	-	105,0	
116	-	-	-	-	-	100,0	99,0	
118	-	-	-	-	-	97,5	93,0	
122	-	-	-	-	-	92,5	81,5	
126	-	-	-	-	-	-	70,0	
130	-	-	-	-	-	-	-	

m	SWSL							SFSL
	0 t		0 t - 640 t					
	85°	85°	75°	65°	55°	45°	t	
36	-	201,0*	-	-	-	-	-	
38	-	200,0*	-	-	-	-	-	
42	-	197,0*	-	-	-	-	-	
44	105,0	203,0	-	-	-	-	203,0	
46	99,0	203,0	-	-	-	-	203,0	
50	88,0	200,0	-	-	-	-	203,0	
54	78,5	198,0	-	-	-	-	201,0	
58	70,5	196,0	-	-	-	-	200,0	
62	63,0	193,0	-	-	-	-	199,0	
66	56,5	179,0	-	-	-	-	195,0	
68	53,5	171,0	193,0	-	-	-	193,5	
70	50,5	163,0	193,0	-	-	-	192,0	
74	44,7	148,0	185,0	-	-	-	188,0	
78	39,1	136,0	168,0	-	-	-	184,0	
82	34,2	124,5	153,0	-	-	-	173,0	
86	29,8	114,5	140,0	-	-	-	164,0	
90	25,8	105,5	128,0	156,0	-	-	155,0	
94	22,3	97,5	118,0	143,0	-	-	147,0	
96	20,6	94,0	113,0	137,0	-	-	143,0	
98	-	-	109,0	131,0	-	-	139,0	
102	-	-	100,0	120,0	-	-	133,0	
106	-	-	93,0	111,0	-	-	126,0	
108	-	-	89,5	106,0	-	-	122,0	
110	-	-	-	102,0	119,0	-	118,0	
114	-	-	-	94,5	111,0	-	107,0	
118	-	-	-	87,5	103,0	-	100,0	
122	-	-	-	-	95,5	-	91,5	
126	-	-	-	-	88,0	81,5	81,0	
130	-	-	-	-	-	77,0	71,0	
132	-	-	-	-	-	75,0	66,2	
134	-	-	-	-	-	-	61,5	
138	-	-	-	-	-	-	51,5	
142	-	-	-	-	-	-	-	

Remarks · Bemerkungen · Remarques

Main boom angle 88°, 85°, 75°, 65°, 55° and 45°; capacities for intermediate boom positions are calculated by the crane control system IC-1
 Hauptauslegerwinkel 88°, 85°, 75°, 65°, 55° und 45°; Traglasten für Zwischenstellungen des Hauptauslegers werden von der Kransteuerung IC-1 berechnet
 Jarret de flèche principale 88°, 85°, 75°, 65°, 55° et 45°; le système de commande de la grue IC-1 calcule les charges pour les positions intermédiaires de la flèche

* Main boom angle 88° · Hauptauslegerwinkel 88° · Jarret de flèche principale 88°

SWSL / SFSL 15° LIFTING CAPACITIES · TRAGFÄHIGKEITEN · CAPACITÉS DE LEVAGE

☰ 295 t + 60 t ZB	↔ 19-30 m	▬ 10,50 m	360°	DIN/ISO
-------------------	-----------	-----------	------	----------------

54 m + 108 m

↕	SWSL							SFSL
	0 t	0 t - 640 t						
	85°	85°	75°	65°	55°	45°		
m	t	t	t	t	t	t	t	
40	-	154,0*	-	-	-	-	-	
42	-	154,0*	-	-	-	-	-	
46	-	151,0*	-	-	-	-	-	
48	85,5	155,0	-	-	-	-	155,0	
50	80,5	154,0	-	-	-	-	154,0	
54	71,5	152,0	-	-	-	-	154,0	
58	63,5	150,0	-	-	-	-	152,0	
62	56,0	148,0	-	-	-	-	151,0	
66	49,9	146,0	-	-	-	-	149,0	
70	44,2	145,0	-	-	-	-	147,0	
74	39,0	143,0	143,0	-	-	-	144,0	
78	34,2	131,0	143,0	-	-	-	142,0	
82	29,3	120,0	143,0	-	-	-	139,0	
86	24,9	110,0	135,0	-	-	-	137,0	
88	22,8	105,0	129,0	-	-	-	136,0	
90	20,9	101,0	124,0	-	-	-	135,0	
94	17,3	93,0	113,0	-	-	-	132,0	
98	14,0	85,5	104,0	124,0	-	-	125,0	
100	12,5	82,0	100,0	121,0	-	-	121,5	
102	-	78,7	96,0	116,0	-	-	118,0	
106	-	72,7	88,0	106,0	-	-	112,0	
108	-	70,0	84,5	102,0	-	-	109,0	
110	-	-	81,0	97,5	-	-	106,0	
114	-	-	75,0	90,0	-	-	101,0	
118	-	-	69,0	83,0	-	-	96,5	
120	-	-	66,5	79,5	94,5	-	93,7	
122	-	-	-	76,5	90,5	-	91,0	
126	-	-	-	70,5	83,5	-	84,5	
128	-	-	-	68,0	80,0	-	80,7	
130	-	-	-	-	77,0	-	77,0	
134	-	-	-	-	71,0	-	68,5	
136	-	-	-	-	68,5	-	64,0	
138	-	-	-	-	-	62,0	59,5	
142	-	-	-	-	-	58,5	51,5	
144	-	-	-	-	-	57,0	47,3	
146	-	-	-	-	-	-	43,2	
150	-	-	-	-	-	-	34,8	

60 m + 36 m

↕	SWSL							SFSL
	0 t	0 t - 640 t						
	85°	85°	75°	65°	55°	45°		
m	t	t	t	t	t	t	t	
18	-	573,0*	-	-	-	-	-	
20	-	564,0*	-	-	-	-	-	
22	-	545,0*	-	-	-	-	-	
24	280,0	600,0	-	-	-	-	584,0	
26	259,0	587,0	-	-	-	-	584,0	
28	240,0	574,0	-	-	-	-	584,0	
30	223,0	556,0	-	-	-	-	584,0	
34	195,0	459,0	-	-	-	-	584,0	
38	166,0	389,0	-	-	-	-	570,0	
39	160,5	375,0	568,0	-	-	-	562,0	
42	144,0	337,0	513,0	-	-	-	527,0	
46	-	-	429,0	-	-	-	473,0	
50	-	-	367,0	-	-	-	426,0	
52	-	-	341,0	-	-	-	406,0	
54	-	-	-	390,0	-	-	386,0	
58	-	-	-	360,0	-	-	352,0	
62	-	-	-	334,0	-	-	322,0	
63	-	-	-	328,0	-	-	313,7	
66	-	-	-	-	-	-	289,0	
67	-	-	-	-	282,0	-	281,0	
70	-	-	-	-	267,0	-	257,0	
72	-	-	-	-	258,0	-	242,5	
74	-	-	-	-	-	-	228,0	
78	-	-	-	-	-	202,0	202,0	
80	-	-	-	-	-	196,0	191,5	
82	-	-	-	-	-	-	184,0	
86	-	-	-	-	-	-	165,0	

60 m + 48 m

m	t	t	t	t	t	t	t
22	-	457,0*	-	-	-	-	-
24	-	446,0*	-	-	-	-	-
26	-	434,0*	-	-	-	-	-
28	225,0	476,0	-	-	-	-	463,0
30	209,0	468,0	-	-	-	-	463,0
34	183,0	453,0	-	-	-	-	463,0
38	162,0	419,0	-	-	-	-	463,0
42	141,0	362,0	-	-	-	-	462,0
45	127,5	327,5	464,0	-	-	-	447,0
46	123,0	317,0	461,0	-	-	-	441,0
50	109,0	281,0	394,0	-	-	-	418,0
54	97,5	248,0	342,0	-	-	-	389,0
58	-	-	302,0	-	-	-	354,0
62	-	-	269,0	327,0	-	-	324,0
64	-	-	255,0	316,0	-	-	310,5
66	-	-	-	305,0	-	-	297,0
70	-	-	-	284,0	-	-	274,0
74	-	-	-	255,0	-	-	247,0
75	-	-	-	248,0	-	-	240,7
76	-	-	-	-	235,0	-	234,5
78	-	-	-	-	227,0	-	222,0
82	-	-	-	-	213,0	-	199,0
84	-	-	-	-	207,0	-	188,0
86	-	-	-	-	-	-	177,0
89	-	-	-	-	-	164,0	162,2
90	-	-	-	-	-	161,0	159,0
92	-	-	-	-	-	157,0	153,5
94	-	-	-	-	-	-	148,0
98	-	-	-	-	-	-	129,0

Remarks · Bemerkungen · Remarques

Main boom angle 88°, 85°, 75°, 65°, 55° and 45°;
 capacities for intermediate boom positions are calculated by the crane control system IC-1

Hauptauslegerwinkel 88°, 85°, 75°, 65°, 55° und 45°;
 Traglasten für Zwischenstellungen des Hauptauslegers werden von der Kransteuerung IC-1 berechnet

Jarret de flèche principale 88°, 85°, 75°, 65°, 55° et 45°;
 le système de commande de la grue IC-1 calcule les charges pour les positions intermédiaires de la flèche

* Main boom angle 88° · Hauptauslegerwinkel 88° · Jarret de flèche principale 88°

SWSL / SFSL15° LIFTING CAPACITIES · TRAGFÄHIGKEITEN · CAPACITÉS DE LEVAGE

295 t + 60 t ZB
↔ 19-30 m
■ 10,50 m
360°
DIN/ISO

60 m + 60 m

60 m + 72 m

m	SWSL							SFSL
	0 t		0 t - 640 t					
	85°	85°	75°	65°	55°	45°	t	
26	-	364,0*	-	-	-	-	-	
28	-	357,0*	-	-	-	-	-	
30	-	350,0*	-	-	-	-	-	
32	184,0	380,0	-	-	-	-	370,0	
34	172,0	376,0	-	-	-	-	370,0	
38	152,0	367,0	-	-	-	-	370,0	
42	136,0	357,0	-	-	-	-	370,0	
46	122,0	333,0	-	-	-	-	370,0	
50	108,0	295,0	-	-	-	-	363,0	
52	102,0	278,0	384,0	-	-	-	354,5	
54	96,5	264,0	360,0	-	-	-	347,0	
58	86,0	238,0	316,0	-	-	-	334,0	
62	77,5	216,0	282,0	-	-	-	321,0	
66	70,0	182,0	253,0	-	-	-	302,0	
69	-	-	234,5	286,0	-	-	284,0	
70	-	-	229,0	282,0	-	-	278,0	
74	-	-	208,0	264,0	-	-	257,0	
76	-	-	199,0	252,0	-	-	248,0	
78	-	-	-	240,0	-	-	239,0	
82	-	-	-	218,0	-	-	217,0	
86	-	-	-	199,0	198,0	-	196,0	
90	-	-	-	-	186,0	-	177,0	
94	-	-	-	-	176,0	-	158,0	
95	-	-	-	-	174,0	-	153,7	
98	-	-	-	-	-	-	141,0	
99	-	-	-	-	-	139,0	137,7	
102	-	-	-	-	-	134,0	131,0	
103	-	-	-	-	-	132,0	127,7	
106	-	-	-	-	-	-	118,0	
110	-	-	-	-	-	-	103,0	
114	-	-	-	-	-	-	-	

m	SWSL							SFSL
	0 t		0 t - 640 t					
	85°	85°	75°	65°	55°	45°	t	
30	-	293,0*	-	-	-	-	-	
34	-	284,0*	-	-	-	-	-	
36	152,0	304,0	-	-	-	-	298,0	
38	143,0	303,0	-	-	-	-	298,0	
42	127,0	297,0	-	-	-	-	298,0	
46	113,0	292,0	-	-	-	-	298,0	
50	102,0	285,0	-	-	-	-	298,0	
54	92,0	266,0	-	-	-	-	295,0	
58	83,0	239,0	310,0	-	-	-	286,0	
62	74,5	216,0	284,0	-	-	-	278,0	
66	66,5	197,0	254,0	-	-	-	268,0	
70	59,5	180,0	229,0	-	-	-	260,0	
74	53,5	158,0	208,0	-	-	-	251,0	
76	50,5	147,0	199,0	-	-	-	245,5	
77	-	-	194,5	243,0	-	-	242,7	
78	-	-	190,0	241,0	-	-	240,0	
82	-	-	174,0	218,0	-	-	223,0	
86	-	-	160,0	198,0	-	-	207,0	
90	-	-	-	181,0	-	-	188,0	
94	-	-	-	166,0	-	-	171,0	
95	-	-	-	162,5	168,0	-	167,0	
96	-	-	-	159,0	166,0	-	163,0	
98	-	-	-	-	161,0	-	155,0	
102	-	-	-	-	152,0	-	139,0	
106	-	-	-	-	144,0	-	125,0	
110	-	-	-	-	-	115,0	114,0	
114	-	-	-	-	-	110,0	106,0	
118	-	-	-	-	-	-	93,0	
122	-	-	-	-	-	-	80,0	
126	-	-	-	-	-	-	-	
130	-	-	-	-	-	-	-	

Remarks · Bemerkungen · Remarques

Main boom angle 88°, 85°, 75°, 65°, 55° and 45°; capacities for intermediate boom positions are calculated by the crane control system IC-1
 Hauptauslegerwinkel 88°, 85°, 75°, 65°, 55° und 45°; Traglasten für Zwischenstellungen des Hauptauslegers werden von der Kransteuerung IC-1 berechnet
 Jarret de flèche principale 88°, 85°, 75°, 65°, 55° et 45°; le système de commande de la grue IC-1 calcule les charges pour les positions intermédiaires de la flèche

* Main boom angle 88° · Hauptauslegerwinkel 88° · Jarret de flèche principale 88°

SWSL / SFSL 15° LIFTING CAPACITIES · TRAGFÄHIGKEITEN · CAPACITÉS DE LEVAGE

295 t + 60 t ZB	19-30 m	10,50 m	360°	DIN/ISO
-----------------	---------	---------	------	----------------

		SWSL						SFSL
		0 t		0 t - 640 t				
		85°	85°	75°	65°	55°	45°	
		t	t	t	t	t	t	t
60 m + 84 m	32	-	237,0*	-	-	-	-	-
	34	-	236,0*	-	-	-	-	-
	38	-	230,0*	-	-	-	-	-
	40	123,0	244,0	-	-	-	-	240,0
	42	116,0	243,0	-	-	-	-	240,0
	46	103,0	240,0	-	-	-	-	240,0
	50	92,0	236,0	-	-	-	-	240,0
	54	82,5	232,0	-	-	-	-	240,0
	58	74,0	228,0	-	-	-	-	240,0
	62	67,0	210,0	-	-	-	-	235,0
	64	63,5	200,0	242,0	-	-	-	232,0
	66	59,5	190,0	242,0	-	-	-	229,0
	70	52,5	173,0	223,0	-	-	-	223,0
	74	46,7	159,0	202,0	-	-	-	217,0
	78	41,3	146,0	183,0	-	-	-	211,0
	82	36,5	133,0	167,0	-	-	-	204,0
	86	32,3	117,5	153,0	192,0	-	-	193,0
	88	30,4	109,0	147,0	183,0	-	-	188,5
	90	-	-	141,0	175,0	-	-	184,0
	94	-	-	130,0	160,0	-	-	175,0
	98	-	-	120,0	147,0	-	-	159,0
	102	-	-	-	135,0	-	-	145,0
	104	-	-	-	130,0	139,0	-	138,0
	106	-	-	-	125,0	135,0	-	131,0
	108	-	-	-	120,0	131,0	-	124,5
	110	-	-	-	-	127,0	-	118,0
	114	-	-	-	-	121,0	-	105,0
	118	-	-	-	-	115,0	-	96,0
	120	-	-	-	-	-	93,5	92,7
	122	-	-	-	-	-	91,5	89,5
	126	-	-	-	-	-	87,0	79,0
	130	-	-	-	-	-	-	68,0
	134	-	-	-	-	-	-	57,0
	138	-	-	-	-	-	-	-
	142	-	-	-	-	-	-	-

		SWSL						SFSL
		0 t		0 t - 640 t				
		85°	85°	75°	65°	55°	45°	
		t	t	t	t	t	t	t
60 m + 96 m	36	-	190,0*	-	-	-	-	-
	38	-	189,0*	-	-	-	-	-
	42	-	185,0*	-	-	-	-	-
	44	101,0	193,0	-	-	-	-	192,0
	46	95,0	193,0	-	-	-	-	192,0
	50	84,5	190,0	-	-	-	-	192,0
	54	75,0	188,0	-	-	-	-	191,0
	58	67,0	186,0	-	-	-	-	191,0
	62	60,0	184,0	-	-	-	-	190,0
	66	53,5	181,0	-	-	-	-	187,0
	70	48,0	171,0	185,0	-	-	-	184,0
	74	42,8	156,0	185,0	-	-	-	181,0
	78	37,9	143,0	181,0	-	-	-	178,0
	82	33,0	131,5	165,0	-	-	-	174,0
	86	28,6	121,0	151,0	-	-	-	171,0
	90	24,7	111,5	138,0	-	-	-	167,0
	92	22,9	107,0	133,0	165,0	-	-	163,0
	94	21,2	101,5	127,0	158,0	-	-	159,0
	98	18,1	89,7	117,0	144,0	-	-	151,0
	100	16,7	83,5	113,0	138,0	-	-	147,5
	102	-	-	108,0	133,0	-	-	144,0
	106	-	-	100,0	122,0	-	-	137,0
	110	-	-	93,0	113,0	-	-	126,0
	114	-	-	-	104,0	116,0	-	114,0
	118	-	-	-	96,5	109,0	-	102,0
	120	-	-	-	93,0	106,0	-	97,0
	122	-	-	-	-	103,0	-	92,0
	126	-	-	-	-	98,0	-	82,5
	128	-	-	-	-	95,0	-	79,5
	130	-	-	-	-	-	77,5	76,5
	134	-	-	-	-	-	73,5	69,0
	136	-	-	-	-	-	72,0	64,2
	138	-	-	-	-	-	-	59,5
	142	-	-	-	-	-	-	50,0
	146	-	-	-	-	-	-	-



Remarks · Bemerkungen · Remarques

Main boom angle 88°, 85°, 75°, 65°, 55° and 45°; capacities for intermediate boom positions are calculated by the crane control system IC-1
 Hauptauslegerwinkel 88°, 85°, 75°, 65°, 55° und 45°; Traglasten für Zwischenstellungen des Hauptauslegers werden von der Kransteuerung IC-1 berechnet
 Jarret de flèche principale 88°, 85°, 75°, 65°, 55° et 45°; le système de commande de la grue IC-1 calcule les charges pour les positions intermédiaires de la flèche



* Main boom angle 88° · Hauptauslegerwinkel 88° · Jarret de flèche principale 88°

SWSL / SFSL15° LIFTING CAPACITIES · TRAGFÄHIGKEITEN · CAPACITÉS DE LEVAGE



 295 t + 60 t ZB
 19-30 m
 10,50 m
360°
DIN/ISO

 60 m +  108 m

m	SWSL						SFSL
	0 t		0 t - 640 t				
	85°	85°	75°	65°	55°	45°	t
40	-	147,0*	-	-	-	-	-
42	-	146,0*	-	-	-	-	-
46	-	143,0*	-	-	-	-	-
48	81,5	147,0	-	-	-	-	147,0
50	76,5	147,0	-	-	-	-	147,0
54	68,0	145,0	-	-	-	-	147,0
58	60,0	144,0	-	-	-	-	146,0
62	53,0	142,0	-	-	-	-	144,0
66	47,1	140,0	-	-	-	-	143,0
70	41,5	138,0	-	-	-	-	141,0
74	36,5	137,0	-	-	-	-	139,0
76	34,2	136,0	135,0	-	-	-	138,0
78	31,9	135,0	135,0	-	-	-	137,0
82	27,8	127,0	135,0	-	-	-	135,0
84	25,8	121,0	135,0	-	-	-	133,5
86	23,7	116,5	135,0	-	-	-	132,0
90	19,7	107,5	134,0	-	-	-	130,0
94	16,1	99,0	123,0	-	-	-	128,0
98	12,9	91,2	113,0	-	-	-	125,0
100	11,4	87,5	108,0	119,0	-	-	124,0
102	-	84,0	104,0	119,0	-	-	123,0
106	-	75,7	95,5	117,0	-	-	121,0
108	-	71,0	92,0	112,0	-	-	118,5
110	-	-	88,0	108,0	-	-	116,0
114	-	-	81,5	99,5	-	-	110,0
118	-	-	75,5	92,0	-	-	105,0
122	-	-	69,5	85,0	97,0	-	96,5
126	-	-	-	78,5	91,5	-	86,5
130	-	-	-	72,5	86,5	-	77,0
132	-	-	-	70,0	83,5	-	72,5
134	-	-	-	-	80,5	-	69,0
138	-	-	-	-	74,5	-	64,0
140	-	-	-	-	71,5	-	60,7
142	-	-	-	-	-	59,5	57,5
146	-	-	-	-	-	56,0	49,5
148	-	-	-	-	-	54,5	45,5
150	-	-	-	-	-	-	41,5
154	-	-	-	-	-	-	33,4
158	-	-	-	-	-	-	-

 66 m +  36 m

m	SWSL						SFSL
	0 t		0 t - 640 t				
	85°	85°	75°	65°	55°	45°	t
18	-	536,0*	-	-	-	-	-
20	-	528,0*	-	-	-	-	-
22	-	511,0*	-	-	-	-	-
24	270,0	562,0	-	-	-	-	546,0
26	249,0	551,0	-	-	-	-	546,0
28	231,0	539,0	-	-	-	-	546,0
30	216,0	528,0	-	-	-	-	546,0
34	189,0	469,0	-	-	-	-	546,0
38	164,0	396,0	-	-	-	-	538,0
41	147,5	354,5	537,0	-	-	-	520,0
42	142,0	342,0	530,0	-	-	-	513,0
46	-	-	457,0	-	-	-	468,0
50	-	-	388,0	-	-	-	421,0
54	-	-	335,0	-	-	-	381,0
56	-	-	-	366,0	-	-	363,5
58	-	-	-	352,0	-	-	346,0
62	-	-	-	326,0	-	-	316,0
66	-	-	-	304,0	-	-	290,0
70	-	-	-	-	-	-	267,0
71	-	-	-	-	264,0	-	260,5
74	-	-	-	-	252,0	-	241,0
76	-	-	-	-	244,0	-	228,0
78	-	-	-	-	-	-	215,0
82	-	-	-	-	-	-	190,0
86	-	-	-	-	-	-	167,0
90	-	-	-	-	-	-	153,0
94	-	-	-	-	-	-	-

 66 m +  48 m

m	t	t	t	t	t	t	t
22	-	424,0*	-	-	-	-	-
24	-	419,0*	-	-	-	-	-
26	-	408,0*	-	-	-	-	-
28	216,0	445,0	-	-	-	-	433,0
30	202,0	441,0	-	-	-	-	433,0
34	177,0	427,0	-	-	-	-	433,0
38	156,0	412,0	-	-	-	-	433,0
42	139,0	368,0	-	-	-	-	433,0
46	122,0	321,0	-	-	-	-	422,0
47	118,0	311,5	441,0	-	-	-	416,5
50	107,0	285,0	417,0	-	-	-	401,0
54	95,5	255,0	360,0	-	-	-	383,0
58	-	-	316,0	-	-	-	349,0
62	-	-	280,0	-	-	-	319,0
64	-	-	265,0	308,0	-	-	306,0
66	-	-	251,0	297,0	-	-	293,0
70	-	-	-	278,0	-	-	269,0
74	-	-	-	261,0	-	-	248,0
77	-	-	-	249,0	-	-	234,5
78	-	-	-	-	-	-	230,0
80	-	-	-	-	222,0	-	219,5
82	-	-	-	-	215,0	-	209,0
86	-	-	-	-	202,0	-	187,0
87	-	-	-	-	200,0	-	182,0
90	-	-	-	-	-	-	167,0
93	-	-	-	-	-	154,0	152,7
94	-	-	-	-	-	152,0	148,0
96	-	-	-	-	-	148,0	139,0
98	-	-	-	-	-	-	133,0
102	-	-	-	-	-	-	123,0
106	-	-	-	-	-	-	-

Remarks · Bemerkungen · Remarques

Main boom angle 88°, 85°, 75°, 65°, 55° and 45°;
capacities for intermediate boom positions are calculated by the crane control system IC-1

Hauptauslegerwinkel 88°, 85°, 75°, 65°, 55° und 45°;
Traglasten für Zwischenstellungen des Hauptauslegers werden von der Kransteuerung IC-1 berechnet

Jarret de flèche principale 88°, 85°, 75°, 65°, 55° et 45°;
le système de commande de la grue IC-1 calcule les charges pour les positions intermédiaires de la flèche

* Main boom angle 88° · Hauptauslegerwinkel 88° · Jarret de flèche principale 88°

SWSL / SFSL 15° LIFTING CAPACITIES · TRAGFÄHIGKEITEN · CAPACITÉS DE LEVAGE

 295 t + 60 t ZB 19-30 m 10,50 m 360° **DIN/ISO**

66 m + 60 m

m	SWSL						SFSL
	0 t		0 t - 640 t				
	85°	85°	75°	65°	55°	45°	t
26	-	344,0*	-	-	-	-	-
28	-	337,0*	-	-	-	-	-
30	-	331,0*	-	-	-	-	-
32	177,0	357,0	-	-	-	-	349,0
34	166,0	355,0	-	-	-	-	349,0
38	147,0	346,0	-	-	-	-	349,0
42	131,0	337,0	-	-	-	-	349,0
46	117,0	328,0	-	-	-	-	349,0
50	106,0	299,0	-	-	-	-	345,0
54	95,0	267,0	367,0	-	-	-	333,0
58	84,5	240,0	332,0	-	-	-	318,0
62	76,0	218,0	294,0	-	-	-	306,0
66	68,5	188,0	263,0	-	-	-	294,0
70	-	-	237,0	-	-	-	274,0
72	-	-	226,0	266,0	-	-	263,5
74	-	-	215,0	257,0	-	-	253,0
78	-	-	197,0	242,0	-	-	234,0
82	-	-	-	228,0	-	-	217,0
86	-	-	-	210,0	-	-	202,0
88	-	-	-	201,0	-	-	193,5
89	-	-	-	-	191,0	-	189,2
90	-	-	-	-	188,0	-	185,0
94	-	-	-	-	177,0	-	167,0
98	-	-	-	-	168,0	-	150,0
102	-	-	-	-	-	-	134,0
103	-	-	-	-	-	130,0	130,2
106	-	-	-	-	-	125,0	119,0
107	-	-	-	-	-	124,0	115,2
110	-	-	-	-	-	-	109,0
114	-	-	-	-	-	-	98,5
118	-	-	-	-	-	-	-

66 m + 72 m

m	SWSL						SFSL
	0 t		0 t - 640 t				
	85°	85°	75°	65°	55°	45°	t
30	-	277,0*	-	-	-	-	-
34	-	269,0*	-	-	-	-	-
36	146,0	288,0	-	-	-	-	282,0
38	137,0	287,0	-	-	-	-	282,0
42	122,0	282,0	-	-	-	-	282,0
46	109,0	276,0	-	-	-	-	282,0
50	98,0	270,0	-	-	-	-	282,0
54	88,5	264,0	-	-	-	-	282,0
58	80,0	244,0	-	-	-	-	274,0
60	76,0	232,0	295,0	-	-	-	269,0
62	72,5	220,0	293,0	-	-	-	265,0
66	65,0	200,0	267,0	-	-	-	257,0
70	58,0	183,0	240,0	-	-	-	248,0
74	52,0	162,0	217,0	-	-	-	240,0
78	47,0	139,0	198,0	-	-	-	232,0
80	-	-	189,0	230,0	-	-	225,5
82	-	-	181,0	223,0	-	-	219,0
86	-	-	166,0	210,0	-	-	203,0
88	-	-	159,0	202,0	-	-	196,0
90	-	-	-	193,0	-	-	189,0
94	-	-	-	177,0	-	-	176,0
98	-	-	-	162,0	162,0	-	162,0
100	-	-	-	156,0	158,0	-	154,0
102	-	-	-	-	153,0	-	146,0
106	-	-	-	-	145,0	-	132,0
110	-	-	-	-	138,0	-	118,0
114	-	-	-	-	-	107,0	105,0
118	-	-	-	-	-	101,0	95,0
119	-	-	-	-	-	100,0	93,2
122	-	-	-	-	-	-	88,0
126	-	-	-	-	-	-	76,5

Remarks · Bemerkungen · Remarques

Main boom angle 88°, 85°, 75°, 65°, 55° and 45°; capacities for intermediate boom positions are calculated by the crane control system IC-1
 Hauptauslegerwinkel 88°, 85°, 75°, 65°, 55° und 45°; Traglasten für Zwischenstellungen des Hauptauslegers werden von der Kransteuerung IC-1 berechnet
 Jarret de flèche principale 88°, 85°, 75°, 65°, 55° et 45°; le système de commande de la grue IC-1 calcule les charges pour les positions intermédiaires de la flèche

* Main boom angle 88° · Hauptauslegerwinkel 88° · Jarret de flèche principale 88°

3

SWSL / SFSL15° LIFTING CAPACITIES · TRAGFÄHIGKEITEN · CAPACITÉS DE LEVAGE

295 t + 60 t ZB
↔ 19-30 m
■ 10,50 m
360°
DIN/ISO

66 m + 84 m

66 m + 96 m

m	SWSL							SFSL
	0 t		0 t - 640 t					
	85°	85°	75°	65°	55°	45°	t	
32	-	224,0*	-	-	-	-	-	
34	-	224,0*	-	-	-	-	-	
38	-	218,0*	-	-	-	-	-	
40	118,0	232,0	-	-	-	-	228,0	
42	111,0	232,0	-	-	-	-	228,0	
46	98,5	228,0	-	-	-	-	228,0	
50	88,0	225,0	-	-	-	-	228,0	
54	79,0	221,0	-	-	-	-	228,0	
58	70,5	217,0	-	-	-	-	228,0	
62	63,5	213,0	-	-	-	-	224,0	
66	57,0	194,0	232,0	-	-	-	219,0	
70	51,0	177,0	232,0	-	-	-	214,0	
74	45,3	161,0	211,0	-	-	-	209,0	
78	39,9	148,0	191,0	-	-	-	203,0	
82	35,2	135,0	174,0	-	-	-	198,0	
86	31,0	120,0	160,0	-	-	-	193,0	
88	29,1	112,0	153,0	195,0	-	-	189,5	
90	-	-	146,0	187,0	-	-	186,0	
94	-	-	135,0	170,0	-	-	173,0	
98	-	-	124,0	156,0	-	-	161,0	
100	-	-	119,0	149,0	-	-	155,5	
102	-	-	-	143,0	-	-	150,0	
106	-	-	-	132,0	-	-	137,0	
108	-	-	-	127,0	132,0	-	130,5	
110	-	-	-	122,0	128,0	-	124,0	
114	-	-	-	-	121,0	-	111,0	
118	-	-	-	-	115,0	-	100,0	
120	-	-	-	-	112,0	-	94,2	
122	-	-	-	-	-	-	88,5	
124	-	-	-	-	-	84,0	83,0	
126	-	-	-	-	-	81,5	78,5	
130	-	-	-	-	-	77,0	72,5	
134	-	-	-	-	-	-	64,0	
138	-	-	-	-	-	-	54,0	
142	-	-	-	-	-	-	-	
146	-	-	-	-	-	-	-	
150	-	-	-	-	-	-	-	
154	-	-	-	-	-	-	-	
158	-	-	-	-	-	-	-	

m	SWSL							SFSL
	0 t		0 t - 640 t					
	85°	85°	75°	65°	55°	45°	t	
36	-	181,0*	-	-	-	-	-	
38	-	180,0*	-	-	-	-	-	
42	-	176,0*	-	-	-	-	-	
44	96,0	185,0	-	-	-	-	183,0	
46	90,5	185,0	-	-	-	-	183,0	
50	80,0	183,0	-	-	-	-	183,0	
54	71,5	180,0	-	-	-	-	183,0	
58	63,5	178,0	-	-	-	-	183,0	
62	56,5	175,0	-	-	-	-	183,0	
66	50,5	173,0	-	-	-	-	182,0	
70	45,1	170,0	-	-	-	-	178,0	
72	42,5	167,0	178,0	-	-	-	176,5	
74	40,1	159,0	178,0	-	-	-	175,0	
78	35,6	146,0	178,0	-	-	-	172,0	
82	31,4	134,0	173,0	-	-	-	169,0	
86	27,3	123,0	157,0	-	-	-	166,0	
90	23,5	113,5	144,0	-	-	-	162,0	
92	21,7	109,0	138,0	-	-	-	160,5	
94	20,0	103,7	132,0	-	-	-	159,0	
96	18,4	98,5	127,0	159,0	-	-	157,0	
98	16,9	92,0	122,0	154,0	-	-	155,0	
100	15,5	85,5	117,0	147,0	-	-	152,5	
102	-	-	112,0	141,0	-	-	150,0	
106	-	-	104,0	130,0	-	-	140,0	
110	-	-	96,5	119,0	-	-	131,0	
112	-	-	92,5	115,0	-	-	125,0	
114	-	-	-	110,0	-	-	119,0	
118	-	-	-	102,0	110,0	-	107,0	
122	-	-	-	94,5	104,0	-	97,0	
126	-	-	-	-	98,5	-	86,5	
130	-	-	-	-	93,5	-	76,5	
132	-	-	-	-	91,5	-	71,7	
134	-	-	-	-	-	-	67,0	
136	-	-	-	-	-	65,5	64,2	
138	-	-	-	-	-	64,0	61,5	
140	-	-	-	-	-	62,5	58,5	
142	-	-	-	-	-	-	55,5	
146	-	-	-	-	-	-	46,9	
150	-	-	-	-	-	-	37,9	

Remarks · Bemerkungen · Remarques

Main boom angle 88°, 85°, 75°, 65°, 55° and 45°; capacities for intermediate boom positions are calculated by the crane control system IC-1
 Hauptauslegerwinkel 88°, 85°, 75°, 65°, 55° und 45°; Traglasten für Zwischenstellungen des Hauptauslegers werden von der Kransteuerung IC-1 berechnet
 Jarret de flèche principale 88°, 85°, 75°, 65°, 55° et 45°; le système de commande de la grue IC-1 calcule les charges pour les positions intermédiaires de la flèche

* Main boom angle 88° · Hauptauslegerwinkel 88° · Jarret de flèche principale 88°

SWSL / SFSL 15° LIFTING CAPACITIES · TRAGFÄHIGKEITEN · CAPACITÉS DE LEVAGE

295 t + 60 t ZB	19-30 m	10,50 m	360°	DIN/ISO
-----------------	---------	---------	------	----------------

		SWSL						SFSL
		0 t		0 t - 640 t				
		85°	85°	75°	65°	55°	45°	
		t	t	t	t	t	t	t
40	m	-	141,0*	-	-	-	-	-
42	m	-	140,0*	-	-	-	-	-
46	m	-	138,0*	-	-	-	-	-
48	m	77,5	142,0	-	-	-	-	142,0
50	m	72,5	142,0	-	-	-	-	142,0
54	m	64,0	140,0	-	-	-	-	142,0
58	m	56,5	139,0	-	-	-	-	141,0
62	m	50,0	137,0	-	-	-	-	140,0
66	m	44,0	135,0	-	-	-	-	138,0
70	m	38,7	134,0	-	-	-	-	137,0
74	m	33,8	132,0	-	-	-	-	135,0
78	m	29,4	131,0	131,0	-	-	-	133,0
82	m	25,4	127,0	131,0	-	-	-	131,0
84	m	23,5	124,0	131,0	-	-	-	130,0
86	m	21,7	119,0	131,0	-	-	-	129,0
90	m	18,3	109,0	130,0	-	-	-	126,0
94	m	14,9	100,2	128,0	-	-	-	124,0
98	m	11,8	92,7	117,0	-	-	-	122,0
100	m	10,3	89,0	112,0	-	-	-	121,0
102	m	-	85,5	108,0	-	-	-	120,0
104	m	-	82,0	103,0	114,0	-	-	119,0
106	m	-	77,5	99,5	114,0	-	-	118,0
110	m	-	68,0	92,0	114,0	-	-	115,0
112	m	-	63,0	88,0	110,0	-	-	114,0
114	m	-	-	84,5	105,0	-	-	113,0
118	m	-	-	78,5	97,5	-	-	110,0
122	m	-	-	72,5	90,0	-	-	100,0
126	m	-	-	-	83,0	92,0	-	91,0
130	m	-	-	-	77,0	86,5	-	81,5
134	m	-	-	-	71,0	82,0	-	72,5
138	m	-	-	-	-	77,5	-	63,5
142	m	-	-	-	-	73,5	-	55,5
144	m	-	-	-	-	71,5	-	52,2
146	m	-	-	-	-	-	51,0	50,0
150	m	-	-	-	-	-	48,7	45,8
152	m	-	-	-	-	-	47,5	41,9
154	m	-	-	-	-	-	-	38,1
158	m	-	-	-	-	-	-	30,4
162	m	-	-	-	-	-	-	22,5

		SWSL						SFSL
		0 t		0 t - 640 t				
		85°	85°	75°	65°	55°	45°	
		t	t	t	t	t	t	t
20	m	-	484,0*	-	-	-	-	-
22	m	-	469,0*	-	-	-	-	-
24	m	259,0	511,0	-	-	-	-	498,0
26	m	240,0	505,0	-	-	-	-	498,0
28	m	223,0	494,0	-	-	-	-	498,0
30	m	208,0	484,0	-	-	-	-	498,0
34	m	182,0	463,0	-	-	-	-	498,0
38	m	162,0	404,0	-	-	-	-	498,0
42	m	140,0	347,0	502,0	-	-	-	480,0
44	m	131,0	324,0	497,0	-	-	-	466,0
46	m	-	-	474,0	-	-	-	455,0
50	m	-	-	411,0	-	-	-	417,0
54	m	-	-	353,0	-	-	-	376,0
56	m	-	-	329,0	-	-	-	359,0
58	m	-	-	-	-	-	-	342,0
59	m	-	-	-	337,0	-	-	334,2
62	m	-	-	-	318,0	-	-	311,0
66	m	-	-	-	297,0	-	-	285,0
68	m	-	-	-	287,0	-	-	273,5
70	m	-	-	-	-	-	-	262,0
74	m	-	-	-	-	243,0	-	241,0
78	m	-	-	-	-	229,0	-	223,0
79	m	-	-	-	-	226,0	-	217,2
82	m	-	-	-	-	-	-	200,0
86	m	-	-	-	-	-	-	178,0
87	m	-	-	-	-	-	174,0	172,7
89	m	-	-	-	-	-	169,0	162,2
90	m	-	-	-	-	-	-	157,0
94	m	-	-	-	-	-	-	137,0
98	m	-	-	-	-	-	-	127,0
102	m	-	-	-	-	-	-	-

Remarks · Bemerkungen · Remarques

Main boom angle 88°, 85°, 75°, 65°, 55° and 45°; capacities for intermediate boom positions are calculated by the crane control system IC-1
 Hauptauslegerwinkel 88°, 85°, 75°, 65°, 55° und 45°; Traglasten für Zwischenstellungen des Hauptauslegers werden von der Kransteuerung IC-1 berechnet
 Jarret de flèche principale 88°, 85°, 75°, 65°, 55° et 45°; le système de commande de la grue IC-1 calcule les charges pour les positions intermédiaires de la flèche

* Main boom angle 88° · Hauptauslegerwinkel 88° · Jarret de flèche principale 88°

3

SWSL / SFSL 15° LIFTING CAPACITIES · TRAGFÄHIGKEITEN · CAPACITÉS DE LEVAGE

295 t + 60 t ZB
↔ 19-30 m
■ 10,50 m
360°
DIN/ISO

72 m + 48 m

72 m + 60 m

m	SWSL							SFSL
	0 t		0 t - 640 t					
	85°	85°	75°	65°	55°	45°	t	
22	-	390,0*	-	-	-	-	-	
24	-	385,0*	-	-	-	-	-	
26	-	376,0*	-	-	-	-	-	
28	208,0	409,0	-	-	-	-	397,0	
30	194,0	405,0	-	-	-	-	397,0	
34	170,0	392,0	-	-	-	-	397,0	
38	151,0	378,0	-	-	-	-	397,0	
42	134,0	365,0	-	-	-	-	397,0	
46	120,0	326,0	-	-	-	-	392,0	
48	112,0	306,0	414,0	-	-	-	384,0	
50	105,0	288,0	414,0	-	-	-	375,0	
54	94,0	257,0	380,0	-	-	-	359,0	
58	-	-	331,0	-	-	-	345,0	
62	-	-	292,0	-	-	-	315,0	
66	-	-	261,0	-	-	-	288,0	
67	-	-	254,0	285,0	-	-	282,0	
68	-	-	247,0	280,0	-	-	276,0	
70	-	-	-	271,0	-	-	264,0	
74	-	-	-	254,0	-	-	244,0	
78	-	-	-	239,0	-	-	225,0	
80	-	-	-	232,0	-	-	216,5	
82	-	-	-	-	-	-	208,0	
83	-	-	-	-	206,0	-	204,2	
86	-	-	-	-	197,0	-	193,0	
90	-	-	-	-	187,0	-	174,0	
94	-	-	-	-	-	-	156,0	
97	-	-	-	-	-	144,0	143,2	
98	-	-	-	-	-	142,0	139,0	
100	-	-	-	-	-	138,0	130,5	
102	-	-	-	-	-	-	122,0	
106	-	-	-	-	-	-	109,0	

m	SWSL							SFSL
	0 t		0 t - 640 t					
	85°	85°	75°	65°	55°	45°	t	
26	-	317,0*	-	-	-	-	-	
28	-	311,0*	-	-	-	-	-	
30	-	305,0*	-	-	-	-	-	
32	170,0	330,0	-	-	-	-	321,0	
34	159,0	328,0	-	-	-	-	321,0	
38	141,0	320,0	-	-	-	-	321,0	
42	126,0	311,0	-	-	-	-	321,0	
46	113,0	302,0	-	-	-	-	321,0	
50	101,0	293,0	-	-	-	-	321,0	
54	92,0	270,0	335,0	-	-	-	311,0	
58	83,0	243,0	333,0	-	-	-	301,0	
62	74,5	220,0	307,0	-	-	-	288,0	
66	67,0	193,0	274,0	-	-	-	279,0	
70	-	-	246,0	-	-	-	269,0	
74	-	-	223,0	251,0	-	-	249,0	
78	-	-	203,0	236,0	-	-	230,0	
82	-	-	-	222,0	-	-	213,0	
86	-	-	-	209,0	-	-	197,0	
90	-	-	-	198,0	-	-	183,0	
92	-	-	-	-	178,0	-	176,5	
94	-	-	-	-	173,0	-	170,0	
98	-	-	-	-	165,0	-	156,0	
102	-	-	-	-	157,0	-	140,0	
106	-	-	-	-	-	-	125,0	
108	-	-	-	-	-	120,0	118,0	
110	-	-	-	-	-	117,0	111,0	
111	-	-	-	-	-	115,0	107,6	
114	-	-	-	-	-	-	97,5	
118	-	-	-	-	-	-	89,5	
122	-	-	-	-	-	-	-	
126	-	-	-	-	-	-	-	

Remarks · Bemerkungen · Remarques

Main boom angle 88°, 85°, 75°, 65°, 55° and 45°; capacities for intermediate boom positions are calculated by the crane control system IC-1
 Hauptauslegerwinkel 88°, 85°, 75°, 65°, 55° und 45°; Traglasten für Zwischenstellungen des Hauptauslegers werden von der Kransteuerung IC-1 berechnet
 Jarret de flèche principale 88°, 85°, 75°, 65°, 55° et 45°; le système de commande de la grue IC-1 calcule les charges pour les positions intermédiaires de la flèche

* Main boom angle 88° · Hauptauslegerwinkel 88° · Jarret de flèche principale 88°

SWSL / SFSL 15° LIFTING CAPACITIES · TRAGFÄHIGKEITEN · CAPACITÉS DE LEVAGE

295 t + 60 t ZB	19-30 m	10,50 m	360°	DIN/ISO
-----------------	---------	---------	------	----------------

		SWSL						SFSL
		0 t		0 t - 640 t				
		85°	85°	75°	65°	55°	45°	
		t	t	t	t	t	t	t
72 m + 72 m	30	-	257,0*	-	-	-	-	-
	34	-	249,0*	-	-	-	-	-
	36	140,0	266,0	-	-	-	-	260,0
	38	131,0	266,0	-	-	-	-	260,0
	42	117,0	261,0	-	-	-	-	260,0
	46	104,0	256,0	-	-	-	-	260,0
	50	94,0	250,0	-	-	-	-	260,0
	54	84,5	244,0	-	-	-	-	260,0
	58	76,5	238,0	-	-	-	-	256,0
	60	73,0	235,0	272,0	-	-	-	252,5
	62	69,5	224,0	272,0	-	-	-	249,0
	66	63,0	204,0	269,0	-	-	-	242,0
	70	56,5	186,0	251,0	-	-	-	234,0
	74	50,5	166,0	227,0	-	-	-	228,0
	78	45,6	143,0	206,0	-	-	-	221,0
	82	-	-	188,0	217,0	-	-	215,0
	86	-	-	172,0	204,0	-	-	199,0
	90	-	-	157,0	193,0	-	-	185,0
	94	-	-	-	183,0	-	-	172,0
	98	-	-	-	172,0	-	-	160,0
	102	-	-	-	158,0	151,0	-	149,0
	106	-	-	-	-	144,0	-	137,0
	110	-	-	-	-	137,0	-	123,0
	112	-	-	-	-	133,0	-	116,5
	114	-	-	-	-	-	-	110,0
	118	-	-	-	-	-	99,5	98,5
	122	-	-	-	-	-	94,5	86,5
	126	-	-	-	-	-	-	77,5
	130	-	-	-	-	-	-	71,0
	134	-	-	-	-	-	-	-
	138	-	-	-	-	-	-	-

		SWSL						SFSL
		0 t		0 t - 640 t				
		85°	85°	75°	65°	55°	45°	
		t	t	t	t	t	t	t
72 m + 84 m	34	-	208,0*	-	-	-	-	-
	38	-	202,0*	-	-	-	-	-
	42	106,0	216,0	-	-	-	-	211,0
	46	94,0	212,0	-	-	-	-	211,0
	50	84,0	208,0	-	-	-	-	211,0
	54	75,0	205,0	-	-	-	-	211,0
	58	67,0	201,0	-	-	-	-	211,0
	62	60,5	197,0	-	-	-	-	210,0
	66	54,0	193,0	216,0	-	-	-	206,0
	70	48,8	179,0	216,0	-	-	-	202,0
	74	43,8	164,0	216,0	-	-	-	198,0
	78	38,5	150,0	200,0	-	-	-	194,0
	82	33,8	137,5	182,0	-	-	-	188,0
	86	29,7	123,0	166,0	-	-	-	183,0
	88	27,8	115,0	159,0	-	-	-	181,0
	90	-	-	152,0	184,0	-	-	179,0
	94	-	-	140,0	174,0	-	-	169,0
	98	-	-	129,0	165,0	-	-	157,0
	102	-	-	118,0	152,0	-	-	146,0
	106	-	-	-	140,0	-	-	136,0
	110	-	-	-	129,0	-	-	127,0
	112	-	-	-	124,0	123,0	-	121,0
	114	-	-	-	119,0	120,0	-	115,0
	118	-	-	-	-	114,0	-	103,0
	122	-	-	-	-	108,0	-	92,5
	124	-	-	-	-	105,0	-	87,2
	126	-	-	-	-	-	-	82,0
	130	-	-	-	-	-	75,0	71,5
	134	-	-	-	-	-	71,0	62,5
	138	-	-	-	-	-	-	57,5
	142	-	-	-	-	-	-	49,6

3
Remarks · Bemerkungen · Remarques

Main boom angle 88°, 85°, 75°, 65°, 55° and 45°; capacities for intermediate boom positions are calculated by the crane control system IC-1
 Hauptauslegerwinkel 88°, 85°, 75°, 65°, 55° und 45°; Traglasten für Zwischenstellungen des Hauptauslegers werden von der Kransteuerung IC-1 berechnet
 Jarret de flèche principale 88°, 85°, 75°, 65°, 55° et 45°; le système de commande de la grue IC-1 calcule les charges pour les positions intermédiaires de la flèche

* Main boom angle 88° · Hauptauslegerwinkel 88° · Jarret de flèche principale 88°

SWSL / SFSL 15° LIFTING CAPACITIES · TRAGFÄHIGKEITEN · CAPACITÉS DE LEVAGE

295 t + 60 t ZB
↔ 19-30 m
■ 10,50 m
360°
DIN/ISO

72 m + 96 m

72 m + 108 m

m	SWSL						SFSL
	0 t		0 t - 640 t				
	85°	85°	75°	65°	55°	45°	t
36	-	167,0*	-	-	-	-	-
38	-	167,0*	-	-	-	-	-
42	-	164,0*	-	-	-	-	-
46	86,0	173,0	-	-	-	-	170,0
50	76,0	170,0	-	-	-	-	170,0
54	67,5	168,0	-	-	-	-	170,0
58	60,0	166,0	-	-	-	-	170,0
62	53,5	163,0	-	-	-	-	170,0
66	47,6	161,0	-	-	-	-	170,0
70	42,2	158,0	-	-	-	-	167,0
72	39,8	157,0	168,0	-	-	-	166,0
74	37,4	156,0	168,0	-	-	-	165,0
78	33,0	148,0	168,0	-	-	-	162,0
82	29,0	136,0	168,0	-	-	-	159,0
86	25,3	125,0	164,0	-	-	-	157,0
88	23,6	120,0	157,0	-	-	-	155,0
90	22,0	115,5	150,0	-	-	-	153,0
94	18,8	105,5	138,0	-	-	-	150,0
98	15,8	94,0	127,0	150,0	-	-	147,0
100	14,4	88,0	121,0	150,0	-	-	145,5
102	-	-	117,0	150,0	-	-	144,0
106	-	-	108,0	137,0	-	-	137,0
110	-	-	100,0	126,0	-	-	127,0
112	-	-	96,0	121,0	-	-	122,5
114	-	-	-	117,0	-	-	118,0
118	-	-	-	108,0	-	-	110,0
120	-	-	-	104,0	106,0	-	105,0
122	-	-	-	100,0	103,0	-	100,0
124	-	-	-	96,0	100,0	-	94,7
126	-	-	-	-	97,5	-	89,5
130	-	-	-	-	92,5	-	80,0
134	-	-	-	-	87,5	-	70,5
136	-	-	-	-	85,5	-	66,0
138	-	-	-	-	-	-	61,5
140	-	-	-	-	-	59,5	57,0
142	-	-	-	-	-	58,0	52,5
146	-	-	-	-	-	54,5	47,9
150	-	-	-	-	-	-	42,3
154	-	-	-	-	-	-	33,9
158	-	-	-	-	-	-	-
162	-	-	-	-	-	-	-

m	SWSL						SFSL
	0 t		0 t - 640 t				
	85°	85°	75°	65°	55°	45°	t
40	-	133,0*	-	-	-	-	-
42	-	132,0*	-	-	-	-	-
46	-	130,0*	-	-	-	-	-
50	68,5	134,0	-	-	-	-	133,0
54	60,5	132,0	-	-	-	-	133,0
58	53,0	131,0	-	-	-	-	133,0
62	46,8	129,0	-	-	-	-	132,0
66	41,0	127,0	-	-	-	-	131,0
70	35,8	125,0	-	-	-	-	129,0
74	31,1	123,0	-	-	-	-	128,0
78	26,8	121,0	124,0	-	-	-	125,0
80	24,8	120,0	124,0	-	-	-	124,0
82	22,9	119,0	124,0	-	-	-	123,0
86	19,4	116,5	124,0	-	-	-	121,0
90	16,1	110,5	124,0	-	-	-	119,0
94	13,0	102,0	124,0	-	-	-	117,0
96	11,6	98,0	124,0	-	-	-	116,0
98	-	94,2	122,0	-	-	-	115,0
102	-	87,0	112,0	-	-	-	113,0
106	-	79,0	103,0	109,0	-	-	110,0
110	-	69,5	95,0	109,0	-	-	108,0
112	-	64,5	91,5	109,0	-	-	107,0
114	-	-	88,0	109,0	-	-	106,0
118	-	-	81,0	103,0	-	-	104,0
122	-	-	75,0	95,0	-	-	101,0
124	-	-	72,0	91,5	-	-	97,0
126	-	-	-	88,0	-	-	93,0
130	-	-	-	81,0	85,5	-	83,5
134	-	-	-	75,0	80,5	-	75,0
136	-	-	-	72,5	78,5	-	70,5
138	-	-	-	-	76,0	-	66,0
142	-	-	-	-	72,0	-	58,0
146	-	-	-	-	68,5	-	50,0
148	-	-	-	-	66,5	-	46,2
150	-	-	-	-	-	44,4	43,0
154	-	-	-	-	-	41,7	39,4
156	-	-	-	-	-	40,8	36,4
158	-	-	-	-	-	-	33,5
162	-	-	-	-	-	-	26,2
166	-	-	-	-	-	-	18,9
170	-	-	-	-	-	-	-

Remarks · Bemerkungen · Remarques

Main boom angle 88°, 85°, 75°, 65°, 55° and 45°; capacities for intermediate boom positions are calculated by the crane control system IC-1
 Hauptauslegerwinkel 88°, 85°, 75°, 65°, 55° und 45°; Traglasten für Zwischenstellungen des Hauptauslegers werden von der Kransteuerung IC-1 berechnet
 Jarret de flèche principale 88°, 85°, 75°, 65°, 55° et 45°; le système de commande de la grue IC-1 calcule les charges pour les positions intermédiaires de la flèche

* Main boom angle 88° · Hauptauslegerwinkel 88° · Jarret de flèche principale 88°

SWSL / SFSL 15° LIFTING CAPACITIES · TRAGFÄHIGKEITEN · CAPACITÉS DE LEVAGE

295 t + 60 t ZB	19-30 m	10,50 m	360°	DIN/ISO
-----------------	---------	---------	------	----------------

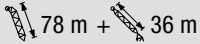
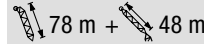
m	SWSL							SFSL
	0 t		0 t - 640 t					t
	85°	85°	75°	65°	55°	45°		
20	-	449,0*	-	-	-	-	-	
22	-	436,0*	-	-	-	-	-	
24	-	422,0*	-	-	-	-	-	
26	230,0	469,0	-	-	-	-	460,0	
28	214,0	459,0	-	-	-	-	460,0	
30	200,0	449,0	-	-	-	-	460,0	
34	175,0	429,0	-	-	-	-	460,0	
38	156,0	410,0	-	-	-	-	460,0	
42	138,0	353,0	-	-	-	-	451,0	
44	129,0	329,0	463,0	-	-	-	439,0	
46	-	-	463,0	-	-	-	427,0	
50	-	-	427,0	-	-	-	408,0	
54	-	-	373,0	-	-	-	372,0	
58	-	-	323,0	-	-	-	337,0	
61	-	-	-	316,0	-	-	314,5	
62	-	-	-	311,0	-	-	307,0	
66	-	-	-	289,0	-	-	280,0	
70	-	-	-	270,0	-	-	257,0	
71	-	-	-	266,0	-	-	251,7	
74	-	-	-	-	-	-	236,0	
77	-	-	-	-	224,0	-	222,5	
78	-	-	-	-	220,0	-	218,0	
82	-	-	-	-	208,0	-	201,0	
86	-	-	-	-	-	-	184,0	
90	-	-	-	-	-	-	164,0	
91	-	-	-	-	-	161,0	159,2	
93	-	-	-	-	-	156,0	149,7	
94	-	-	-	-	-	-	145,0	
98	-	-	-	-	-	-	127,0	
102	-	-	-	-	-	-	112,0	
106	-	-	-	-	-	-	-	

m	SWSL							SFSL
	0 t		0 t - 640 t					t
	85°	85°	75°	65°	55°	45°		
22	-	362,0*	-	-	-	-	-	
24	-	358,0*	-	-	-	-	-	
26	-	349,0*	-	-	-	-	-	
28	-	340,0*	-	-	-	-	-	
30	186,0	377,0	-	-	-	-	368,0	
34	163,0	364,0	-	-	-	-	368,0	
38	145,0	351,0	-	-	-	-	368,0	
42	129,0	338,0	-	-	-	-	368,0	
46	116,0	326,0	-	-	-	-	367,0	
50	103,0	292,0	386,0	-	-	-	355,0	
54	92,0	260,0	379,0	-	-	-	339,0	
56	87,0	240,0	370,0	-	-	-	333,0	
58	-	-	348,0	-	-	-	327,0	
62	-	-	305,0	-	-	-	310,0	
66	-	-	271,0	-	-	-	284,0	
68	-	-	257,0	-	-	-	272,0	
69	-	-	-	268,0	-	-	266,0	
70	-	-	-	264,0	-	-	260,0	
74	-	-	-	247,0	-	-	239,0	
78	-	-	-	232,0	-	-	220,0	
82	-	-	-	219,0	-	-	203,0	
86	-	-	-	-	-	-	188,0	
87	-	-	-	-	187,0	-	184,5	
90	-	-	-	-	179,0	-	174,0	
94	-	-	-	-	170,0	-	161,0	
98	-	-	-	-	-	-	144,0	
102	-	-	-	-	-	131,0	128,0	
104	-	-	-	-	-	127,0	120,5	
106	-	-	-	-	-	-	113,0	
110	-	-	-	-	-	-	98,5	
114	-	-	-	-	-	-	89,5	

Remarks · Bemerkungen · Remarques

Main boom angle 88°, 85°, 75°, 65°, 55° and 45°; capacities for intermediate boom positions are calculated by the crane control system IC-1
 Hauptauslegerwinkel 88°, 85°, 75°, 65°, 55° und 45°; Traglasten für Zwischenstellungen des Hauptauslegers werden von der Kransteuerung IC-1 berechnet
 Jarret de flèche principale 88°, 85°, 75°, 65°, 55° et 45°; le système de commande de la grue IC-1 calcule les charges pour les positions intermédiaires de la flèche

* Main boom angle 88° · Hauptauslegerwinkel 88° · Jarret de flèche principale 88°

3

SWSL / SFSL15° LIFTING CAPACITIES · TRAGFÄHIGKEITEN · CAPACITÉS DE LEVAGE

295 t + 60 t ZB
↔ 19-30 m
■ 10,50 m
360°
DIN/ISO

78 m + 60 m

78 m + 72 m

m	SWSL							SFSL
	0 t		0 t - 640 t					
	85°	85°	75°	65°	55°	45°	t	
26	-	293,0*	-	-	-	-	-	
28	-	290,0*	-	-	-	-	-	
30	-	285,0*	-	-	-	-	-	
34	153,0	307,0	-	-	-	-	299,0	
38	135,0	298,0	-	-	-	-	299,0	
42	120,0	290,0	-	-	-	-	299,0	
46	108,0	282,0	-	-	-	-	299,0	
50	97,5	273,0	-	-	-	-	299,0	
54	88,0	265,0	-	-	-	-	293,0	
56	84,0	259,0	314,0	-	-	-	288,5	
58	80,0	246,0	313,0	-	-	-	284,0	
62	73,0	222,0	307,0	-	-	-	273,0	
66	65,5	195,0	285,0	-	-	-	265,0	
70	-	-	255,0	-	-	-	257,0	
74	-	-	231,0	-	-	-	245,0	
77	-	-	215,0	233,0	-	-	230,7	
78	-	-	210,0	229,0	-	-	226,0	
80	-	-	200,0	222,0	-	-	217,5	
82	-	-	-	216,0	-	-	209,0	
86	-	-	-	204,0	-	-	193,0	
90	-	-	-	193,0	-	-	179,0	
94	-	-	-	183,0	-	-	166,0	
96	-	-	-	-	162,0	-	160,0	
98	-	-	-	-	158,0	-	154,0	
102	-	-	-	-	150,0	-	144,0	
104	-	-	-	-	146,0	-	137,0	
106	-	-	-	-	-	-	130,0	
110	-	-	-	-	-	-	116,0	
112	-	-	-	-	-	111,0	109,5	
114	-	-	-	-	-	108,0	103,0	
116	-	-	-	-	-	105,0	96,5	
118	-	-	-	-	-	-	90,0	
122	-	-	-	-	-	-	78,5	
126	-	-	-	-	-	-	72,5	
130	-	-	-	-	-	-	-	

m	SWSL							SFSL
	0 t		0 t - 640 t					
	85°	85°	75°	65°	55°	45°	t	
30	-	240,0*	-	-	-	-	-	
34	-	233,0*	-	-	-	-	-	
38	126,0	250,0	-	-	-	-	243,0	
42	112,0	244,0	-	-	-	-	243,0	
46	100,0	239,0	-	-	-	-	243,0	
50	89,5	233,0	-	-	-	-	243,0	
54	81,0	228,0	-	-	-	-	243,0	
58	73,0	222,0	-	-	-	-	241,0	
62	66,0	217,0	254,0	-	-	-	235,0	
66	60,0	207,0	254,0	-	-	-	230,0	
70	54,5	189,0	250,0	-	-	-	224,0	
74	49,3	166,0	236,0	-	-	-	216,0	
78	44,1	143,0	214,0	-	-	-	211,0	
82	-	-	196,0	-	-	-	205,0	
86	-	-	179,0	198,0	-	-	195,0	
90	-	-	163,0	187,0	-	-	181,0	
92	-	-	152,0	182,0	-	-	174,5	
94	-	-	-	177,0	-	-	168,0	
98	-	-	-	168,0	-	-	156,0	
102	-	-	-	160,0	-	-	145,0	
104	-	-	-	156,0	-	-	140,0	
106	-	-	-	-	137,0	-	135,0	
110	-	-	-	-	130,0	-	125,0	
114	-	-	-	-	124,0	-	114,0	
116	-	-	-	-	122,0	-	108,0	
118	-	-	-	-	-	-	102,0	
122	-	-	-	-	-	91,5	90,5	
126	-	-	-	-	-	86,5	79,5	
130	-	-	-	-	-	-	68,5	
134	-	-	-	-	-	-	61,5	
138	-	-	-	-	-	-	-	
142	-	-	-	-	-	-	-	
146	-	-	-	-	-	-	-	
150	-	-	-	-	-	-	-	
154	-	-	-	-	-	-	-	

Remarks · Bemerkungen · Remarques

Main boom angle 88°, 85°, 75°, 65°, 55° and 45°; capacities for intermediate boom positions are calculated by the crane control system IC-1
 Hauptauslegerwinkel 88°, 85°, 75°, 65°, 55° und 45°; Traglasten für Zwischenstellungen des Hauptauslegers werden von der Kransteuerung IC-1 berechnet
 Jarret de flèche principale 88°, 85°, 75°, 65°, 55° et 45°; le système de commande de la grue IC-1 calcule les charges pour les positions intermédiaires de la flèche

* Main boom angle 88° · Hauptauslegerwinkel 88° · Jarret de flèche principale 88°

SWSL / SFSL 15° LIFTING CAPACITIES · TRAGFÄHIGKEITEN · CAPACITÉS DE LEVAGE

295 t + 60 t ZB 19-30 m 10,50 m 360° DIN/ISO

78 m + 84 m

78 m + 96 m

m	SWSL						SFSL
	0 t		0 t - 640 t				
	85°	85°	75°	65°	55°	45°	t
34	-	195,0*	-	-	-	-	-
38	-	190,0*	-	-	-	-	-
42	101,0	202,0	-	-	-	-	198,0
46	89,5	199,0	-	-	-	-	198,0
50	79,5	195,0	-	-	-	-	198,0
54	71,0	192,0	-	-	-	-	198,0
58	63,5	188,0	-	-	-	-	198,0
62	57,0	184,0	-	-	-	-	197,0
66	51,0	180,0	-	-	-	-	194,0
68	48,5	179,0	202,0	-	-	-	192,0
70	45,8	177,0	202,0	-	-	-	190,0
74	41,1	168,0	202,0	-	-	-	187,0
78	36,7	154,0	202,0	-	-	-	183,0
82	32,4	139,5	190,0	-	-	-	178,0
86	28,3	123,0	174,0	-	-	-	174,0
88	26,4	115,0	166,0	-	-	-	172,0
90	-	-	159,0	-	-	-	170,0
92	-	-	153,0	173,0	-	-	167,5
94	-	-	147,0	168,0	-	-	165,0
98	-	-	135,0	159,0	-	-	153,0
102	-	-	122,0	151,0	-	-	142,0
104	-	-	114,0	147,0	-	-	137,0
106	-	-	-	143,0	-	-	132,0
110	-	-	-	136,0	-	-	123,0
114	-	-	-	128,0	115,0	-	114,0
116	-	-	-	123,0	112,0	-	109,5
118	-	-	-	-	110,0	-	105,0
122	-	-	-	-	104,0	-	95,0
126	-	-	-	-	100,0	-	84,5
128	-	-	-	-	98,0	-	79,5
130	-	-	-	-	-	-	74,5
134	-	-	-	-	-	68,0	65,0
138	-	-	-	-	-	64,5	55,5
142	-	-	-	-	-	-	48,8
146	-	-	-	-	-	-	44,3
150	-	-	-	-	-	-	-
154	-	-	-	-	-	-	-
158	-	-	-	-	-	-	-
162	-	-	-	-	-	-	-

m	SWSL						SFSL
	0 t		0 t - 640 t				
	85°	85°	75°	65°	55°	45°	t
36	-	157,0*	-	-	-	-	-
38	-	157,0*	-	-	-	-	-
42	-	153,0*	-	-	-	-	-
46	81,5	162,0	-	-	-	-	159,0
50	72,0	160,0	-	-	-	-	159,0
54	63,5	158,0	-	-	-	-	159,0
58	56,5	156,0	-	-	-	-	159,0
62	50,0	153,0	-	-	-	-	159,0
66	44,4	151,0	-	-	-	-	159,0
70	39,3	148,0	-	-	-	-	158,0
74	34,6	146,0	158,0	-	-	-	155,0
78	30,3	143,0	158,0	-	-	-	153,0
82	26,5	138,0	158,0	-	-	-	151,0
84	24,7	135,0	158,0	-	-	-	149,5
86	23,0	129,5	158,0	-	-	-	148,0
90	19,7	118,5	158,0	-	-	-	146,0
94	16,7	106,5	145,0	-	-	-	142,0
98	13,9	93,7	134,0	-	-	-	139,0
100	12,6	87,5	128,0	141,0	-	-	138,0
102	-	-	123,0	141,0	-	-	137,0
106	-	-	114,0	139,0	-	-	133,0
110	-	-	106,0	131,0	-	-	123,0
114	-	-	94,5	125,0	-	-	115,0
118	-	-	-	116,0	-	-	106,0
122	-	-	-	108,0	-	-	99,0
124	-	-	-	104,0	97,0	-	95,0
126	-	-	-	100,0	94,5	-	91,0
128	-	-	-	96,5	92,0	-	86,2
130	-	-	-	-	90,0	-	81,5
134	-	-	-	-	85,5	-	72,5
138	-	-	-	-	81,0	-	63,5
140	-	-	-	-	79,0	-	59,2
142	-	-	-	-	-	-	55,0
144	-	-	-	-	-	53,0	51,0
146	-	-	-	-	-	51,5	47,1
150	-	-	-	-	-	48,8	41,1
154	-	-	-	-	-	-	37,1
158	-	-	-	-	-	-	29,2
162	-	-	-	-	-	-	-

3

Remarks · Bemerkungen · Remarques

Main boom angle 88°, 85°, 75°, 65°, 55° and 45°; capacities for intermediate boom positions are calculated by the crane control system IC-1
 Hauptauslegerwinkel 88°, 85°, 75°, 65°, 55° und 45°; Traglasten für Zwischenstellungen des Hauptauslegers werden von der Kransteuerung IC-1 berechnet
 Jarret de flèche principale 88°, 85°, 75°, 65°, 55° et 45°; le système de commande de la grue IC-1 calcule les charges pour les positions intermédiaires de la flèche

* Main boom angle 88° · Hauptauslegerwinkel 88° · Jarret de flèche principale 88°

SWSL / SFSL 15° LIFTING CAPACITIES · TRAGFÄHIGKEITEN · CAPACITÉS DE LEVAGE

295 t + 60 t ZB
19-30 m
10,50 m
360°
DIN/ISO

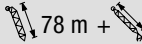
 78 m + 108 m

 84 m + 36 m

m	SWSL						SFSL
	0 t		0 t - 640 t				
	85°	85°	75°	65°	55°	45°	t
40	-	126,0*	-	-	-	-	-
42	-	125,0*	-	-	-	-	-
46	-	123,0*	-	-	-	-	-
50	64,5	127,0	-	-	-	-	127,0
54	56,5	126,0	-	-	-	-	127,0
58	49,6	125,0	-	-	-	-	126,0
62	43,4	123,0	-	-	-	-	126,0
66	37,8	121,0	-	-	-	-	125,0
70	32,8	119,0	-	-	-	-	124,0
74	28,3	117,0	-	-	-	-	123,0
78	24,1	115,0	-	-	-	-	121,0
80	22,2	115,0	119,0	-	-	-	120,0
82	20,4	114,0	119,0	-	-	-	119,0
86	16,9	111,5	119,0	-	-	-	117,0
90	13,8	106,5	119,0	-	-	-	115,0
92	12,3	103,0	119,0	-	-	-	113,5
94	-	99,7	119,0	-	-	-	112,0
98	-	93,2	118,0	-	-	-	110,0
102	-	86,5	118,0	-	-	-	108,0
106	-	78,5	109,0	-	-	-	106,0
108	-	74,0	105,0	104,0	-	-	105,0
110	-	69,0	101,0	104,0	-	-	104,0
112	-	64,0	97,5	104,0	-	-	102,5
114	-	-	93,5	104,0	-	-	101,0
118	-	-	86,5	104,0	-	-	99,5
122	-	-	80,0	103,0	-	-	97,5
126	-	-	70,5	95,5	-	-	90,5
130	-	-	-	88,5	-	-	83,5
134	-	-	-	81,5	78,0	-	76,0
138	-	-	-	76,0	73,5	-	67,5
142	-	-	-	-	69,5	-	59,5
146	-	-	-	-	66,0	-	51,5
150	-	-	-	-	62,5	-	44,2
154	-	-	-	-	-	38,5	36,9
158	-	-	-	-	-	35,9	31,6
160	-	-	-	-	-	34,7	29,5
162	-	-	-	-	-	-	27,5
166	-	-	-	-	-	-	21,5
170	-	-	-	-	-	-	14,5

m	SWSL						SFSL
	0 t		0 t - 640 t				
	85°	85°	75°	65°	55°	45°	t
20	-	411,0*	-	-	-	-	-
22	-	399,0*	-	-	-	-	-
24	-	386,0*	-	-	-	-	-
26	221,0	430,0	-	-	-	-	419,0
28	205,0	421,0	-	-	-	-	419,0
30	192,0	412,0	-	-	-	-	419,0
34	168,0	392,0	-	-	-	-	419,0
38	150,0	374,0	-	-	-	-	419,0
42	134,0	358,0	-	-	-	-	417,0
44	126,0	334,0	-	-	-	-	409,0
45	-	-	430,0	-	-	-	402,5
46	-	-	430,0	-	-	-	397,0
50	-	-	417,0	-	-	-	380,0
54	-	-	385,0	-	-	-	365,0
58	-	-	340,0	-	-	-	332,0
62	-	-	-	-	-	-	302,0
64	-	-	-	291,0	-	-	288,5
66	-	-	-	281,0	-	-	275,0
70	-	-	-	262,0	-	-	252,0
73	-	-	-	250,0	-	-	236,2
74	-	-	-	-	-	-	231,0
78	-	-	-	-	-	-	213,0
81	-	-	-	-	202,0	-	200,2
82	-	-	-	-	199,0	-	196,0
86	-	-	-	-	188,0	-	181,0
90	-	-	-	-	-	-	167,0
94	-	-	-	-	-	-	150,0
95	-	-	-	-	-	147,0	145,7
97	-	-	-	-	-	143,0	137,2
98	-	-	-	-	-	-	133,0
102	-	-	-	-	-	-	116,0
106	-	-	-	-	-	-	100,0
110	-	-	-	-	-	-	-

Remarks · Bemerkungen · Remarques

Main boom angle 88°, 85°, 75°, 65°, 55° and 45°; capacities for intermediate boom positions are calculated by the crane control system IC-1
 Hauptauslegerwinkel 88°, 85°, 75°, 65°, 55° und 45°; Traglasten für Zwischenstellungen des Hauptauslegers werden von der Kransteuerung IC-1 berechnet
 Jarret de flèche principale 88°, 85°, 75°, 65°, 55° et 45°; le système de commande de la grue IC-1 calcule les charges pour les positions intermédiaires de la flèche

* Main boom angle 88° · Hauptauslegerwinkel 88° · Jarret de flèche principale 88°

SWSL / SFSL 15° LIFTING CAPACITIES · TRAGFÄHIGKEITEN · CAPACITÉS DE LEVAGE

295 t + 60 t ZB	19-30 m	10,50 m	360°	DIN/ISO
-----------------	---------	---------	------	----------------

		SWSL						SFSL
		0 t		0 t - 640 t				
		85°	85°	75°	65°	55°	45°	
		t	t	t	t	t	t	t
24	m	-	330,0*	-	-	-	-	-
26	m	-	322,0*	-	-	-	-	-
28	m	-	314,0*	-	-	-	-	-
30	m	178,0	347,0	-	-	-	-	337,0
34	m	156,0	335,0	-	-	-	-	337,0
38	m	139,0	323,0	-	-	-	-	337,0
42	m	124,0	310,0	-	-	-	-	337,0
46	m	111,0	298,0	-	-	-	-	337,0
50	m	101,0	288,0	-	-	-	-	329,0
52	m	95,5	279,0	353,0	-	-	-	323,5
54	m	90,0	263,0	352,0	-	-	-	318,0
56	m	85,0	247,0	348,0	-	-	-	309,0
58	m	-	-	342,0	-	-	-	304,0
62	m	-	-	320,0	-	-	-	293,0
66	m	-	-	283,0	-	-	-	279,0
70	m	-	-	253,0	-	-	-	255,0
72	m	-	-	-	248,0	-	-	244,5
74	m	-	-	-	240,0	-	-	234,0
78	m	-	-	-	225,0	-	-	215,0
82	m	-	-	-	212,0	-	-	199,0
84	m	-	-	-	206,0	-	-	191,0
86	m	-	-	-	-	-	-	183,0
90	m	-	-	-	-	171,0	-	169,0
94	m	-	-	-	-	162,0	-	157,0
97	m	-	-	-	-	156,0	-	148,0
98	m	-	-	-	-	-	-	145,0
102	m	-	-	-	-	-	-	131,0
106	m	-	-	-	-	-	119,0	117,0
109	m	-	-	-	-	-	115,0	106,5
110	m	-	-	-	-	-	-	103,0
114	m	-	-	-	-	-	-	89,5
118	m	-	-	-	-	-	-	77,5
122	m	-	-	-	-	-	-	-
126	m	-	-	-	-	-	-	-
130	m	-	-	-	-	-	-	-

		SWSL						SFSL
		0 t		0 t - 640 t				
		85°	85°	75°	65°	55°	45°	
		t	t	t	t	t	t	t
26	m	-	270,0*	-	-	-	-	-
28	m	-	268,0*	-	-	-	-	-
30	m	-	263,0*	-	-	-	-	-
34	m	146,0	281,0	-	-	-	-	275,0
38	m	129,0	275,0	-	-	-	-	275,0
42	m	115,0	267,0	-	-	-	-	275,0
46	m	103,0	259,0	-	-	-	-	275,0
50	m	93,0	251,0	-	-	-	-	275,0
54	m	84,0	243,0	-	-	-	-	271,0
58	m	76,5	234,0	289,0	-	-	-	264,0
62	m	69,5	225,0	284,0	-	-	-	256,0
66	m	63,5	199,0	279,0	-	-	-	246,0
68	m	60,0	182,0	275,0	-	-	-	242,5
70	m	-	-	266,0	-	-	-	239,0
74	m	-	-	239,0	-	-	-	232,0
78	m	-	-	217,0	-	-	-	221,0
79	m	-	-	212,0	219,0	-	-	216,7
82	m	-	-	198,0	209,0	-	-	204,0
86	m	-	-	-	197,0	-	-	189,0
90	m	-	-	-	187,0	-	-	175,0
94	m	-	-	-	177,0	-	-	162,0
96	m	-	-	-	172,0	-	-	156,0
98	m	-	-	-	-	-	-	150,0
99	m	-	-	-	-	148,0	-	147,2
102	m	-	-	-	-	143,0	-	139,0
106	m	-	-	-	-	136,0	-	129,0
108	m	-	-	-	-	133,0	-	123,5
110	m	-	-	-	-	-	-	118,0
114	m	-	-	-	-	-	-	105,0
116	m	-	-	-	-	-	101,0	99,2
118	m	-	-	-	-	-	98,0	93,5
120	m	-	-	-	-	-	95,5	87,5
122	m	-	-	-	-	-	-	81,5
126	m	-	-	-	-	-	-	70,0
130	m	-	-	-	-	-	-	62,0

3
Remarks · Bemerkungen · Remarques

Main boom angle 88°, 85°, 75°, 65°, 55° and 45°; capacities for intermediate boom positions are calculated by the crane control system IC-1
 Hauptauslegerwinkel 88°, 85°, 75°, 65°, 55° und 45°; Traglasten für Zwischenstellungen des Hauptauslegers werden von der Kransteuerung IC-1 berechnet
 Jarret de flèche principale 88°, 85°, 75°, 65°, 55° et 45°; le système de commande de la grue IC-1 calcule les charges pour les positions intermédiaires de la flèche

* Main boom angle 88° · Hauptauslegerwinkel 88° · Jarret de flèche principale 88°

SWSL / SFSL15° LIFTING CAPACITIES · TRAGFÄHIGKEITEN · CAPACITÉS DE LEVAGE

295 t + 60 t ZB
19-30 m
10,50 m
360°
DIN/ISO

84 m + 72 m

84 m + 84 m

m	SWSL							SFSL
	0 t		0 t - 640 t					
	85°	85°	75°	65°	55°	45°	t	
30	-	220,0*	-	-	-	-	-	
34	-	215,0*	-	-	-	-	-	
38	120,0	230,0	-	-	-	-	224,0	
42	106,0	225,0	-	-	-	-	224,0	
46	95,0	220,0	-	-	-	-	224,0	
50	85,5	215,0	-	-	-	-	224,0	
54	76,5	209,0	-	-	-	-	224,0	
58	69,0	204,0	-	-	-	-	224,0	
62	62,5	199,0	-	-	-	-	219,0	
64	59,5	195,0	233,0	-	-	-	216,5	
66	56,5	192,0	233,0	-	-	-	214,0	
70	51,5	185,0	232,0	-	-	-	210,0	
74	46,7	169,0	226,0	-	-	-	205,0	
78	42,4	147,0	222,0	-	-	-	198,0	
82	-	-	202,0	-	-	-	193,0	
86	-	-	185,0	-	-	-	188,0	
88	-	-	177,0	187,0	-	-	182,5	
90	-	-	170,0	181,0	-	-	177,0	
94	-	-	150,0	172,0	-	-	164,0	
98	-	-	-	163,0	-	-	152,0	
102	-	-	-	154,0	-	-	141,0	
106	-	-	-	147,0	-	-	131,0	
108	-	-	-	-	127,0	-	126,0	
110	-	-	-	-	124,0	-	121,0	
114	-	-	-	-	118,0	-	112,0	
118	-	-	-	-	113,0	-	103,0	
120	-	-	-	-	110,0	-	97,7	
122	-	-	-	-	-	-	92,5	
126	-	-	-	-	-	-	81,5	
128	-	-	-	-	-	80,0	76,5	
130	-	-	-	-	-	78,0	71,5	
134	-	-	-	-	-	-	61,0	
138	-	-	-	-	-	-	52,0	
142	-	-	-	-	-	-	47,8	
146	-	-	-	-	-	-	-	

m	SWSL							SFSL
	0 t		0 t - 640 t					
	85°	85°	75°	65°	55°	45°	t	
34	-	180,0*	-	-	-	-	-	
38	-	175,0*	-	-	-	-	-	
42	95,5	186,0	-	-	-	-	182,0	
46	85,0	184,0	-	-	-	-	182,0	
50	75,5	180,0	-	-	-	-	182,0	
54	67,0	177,0	-	-	-	-	182,0	
58	60,0	173,0	-	-	-	-	182,0	
62	53,5	169,0	-	-	-	-	182,0	
66	47,9	166,0	-	-	-	-	180,0	
70	42,8	162,0	186,0	-	-	-	177,0	
74	38,1	157,0	186,0	-	-	-	174,0	
78	33,9	152,0	186,0	-	-	-	171,0	
82	30,1	141,0	185,0	-	-	-	168,0	
86	26,6	125,0	179,0	-	-	-	163,0	
88	24,9	117,0	172,0	-	-	-	161,5	
90	-	-	164,0	-	-	-	160,0	
94	-	-	151,0	-	-	-	157,0	
96	-	-	145,0	158,0	-	-	153,0	
98	-	-	139,0	154,0	-	-	149,0	
102	-	-	129,0	145,0	-	-	138,0	
104	-	-	121,0	142,0	-	-	133,0	
106	-	-	-	138,0	-	-	128,0	
110	-	-	-	131,0	-	-	118,0	
114	-	-	-	125,0	-	-	110,0	
118	-	-	-	119,0	103,0	-	101,0	
122	-	-	-	-	98,5	-	94,0	
126	-	-	-	-	93,5	-	85,5	
130	-	-	-	-	89,5	-	75,5	
132	-	-	-	-	87,5	-	71,0	
134	-	-	-	-	-	-	66,5	
138	-	-	-	-	-	60,0	57,5	
142	-	-	-	-	-	57,0	48,7	
146	-	-	-	-	-	-	41,5	
150	-	-	-	-	-	-	37,2	
154	-	-	-	-	-	-	29,5	

Remarks · Bemerkungen · Remarques

Main boom angle 88°, 85°, 75°, 65°, 55° and 45°; capacities for intermediate boom positions are calculated by the crane control system IC-1
 Hauptauslegerwinkel 88°, 85°, 75°, 65°, 55° und 45°; Traglasten für Zwischenstellungen des Hauptauslegers werden von der Kransteuerung IC-1 berechnet
 Jarret de flèche principale 88°, 85°, 75°, 65°, 55° et 45°; le système de commande de la grue IC-1 calcule les charges pour les positions intermédiaires de la flèche

* Main boom angle 88° · Hauptauslegerwinkel 88° · Jarret de flèche principale 88°

SWSL / SFSL 15° LIFTING CAPACITIES · TRAGFÄHIGKEITEN · CAPACITÉS DE LEVAGE

 295 t + 60 t ZB	 19-30 m	 10,50 m	 360°	DIN/ISO
---	---	---	--	----------------

		SWSL						SFSL
		0 t		0 t - 640 t				
		85°	85°	75°	65°	55°	45°	
		t	t	t	t	t	t	t
84 m + 96 m	38	-	145,0*	-	-	-	-	-
	42	-	142,0*	-	-	-	-	-
	46	76,5	150,0	-	-	-	-	147,0
	50	67,5	148,0	-	-	-	-	147,0
	54	59,5	146,0	-	-	-	-	147,0
	58	52,5	143,0	-	-	-	-	147,0
	62	46,7	141,0	-	-	-	-	147,0
	66	41,2	138,0	-	-	-	-	147,0
	70	36,2	136,0	-	-	-	-	146,0
	74	31,7	133,0	-	-	-	-	144,0
	76	29,6	132,0	146,0	-	-	-	143,0
	78	27,6	131,0	146,0	-	-	-	142,0
	80	25,7	129,0	146,0	-	-	-	141,0
	82	23,9	127,0	146,0	-	-	-	140,0
	86	20,4	123,0	146,0	-	-	-	138,0
	90	17,3	117,5	146,0	-	-	-	136,0
	94	14,4	108,0	146,0	-	-	-	134,0
	98	11,7	95,7	137,0	-	-	-	130,0
	100	10,5	89,5	132,0	-	-	-	129,0
	102	-	-	127,0	-	-	-	128,0
	104	-	-	122,0	124,0	-	-	127,0
	106	-	-	117,0	124,0	-	-	126,0
	110	-	-	108,0	123,0	-	-	119,0
	114	-	-	99,5	120,0	-	-	111,0
	116	-	-	93,0	117,0	-	-	106,5
	118	-	-	-	114,0	-	-	102,0
	122	-	-	-	108,0	-	-	95,0
	126	-	-	-	103,0	-	-	87,5
	128	-	-	-	101,0	86,0	-	84,2
	130	-	-	-	97,5	84,0	-	81,0
	134	-	-	-	-	80,0	-	73,0
	138	-	-	-	-	76,0	-	64,0
	142	-	-	-	-	73,0	-	56,0
	146	-	-	-	-	-	-	48,1
	148	-	-	-	-	-	46,2	44,2
	150	-	-	-	-	-	44,8	40,3
	154	-	-	-	-	-	42,0	33,0
	158	-	-	-	-	-	-	28,7
	162	-	-	-	-	-	-	23,4

		SWSL						SFSL
		0 t		0 t - 640 t				
		85°	85°	75°	65°	55°	45°	
		t	t	t	t	t	t	t
84 m + 108 m	40	-	117,0*	-	-	-	-	-
	42	-	117,0*	-	-	-	-	-
	46	-	114,0*	-	-	-	-	-
	50	60,0	119,0	-	-	-	-	118,0
	54	52,5	118,0	-	-	-	-	118,0
	58	45,8	116,0	-	-	-	-	118,0
	62	39,9	114,0	-	-	-	-	117,0
	66	34,5	113,0	-	-	-	-	117,0
	70	29,8	111,0	-	-	-	-	116,0
	74	25,3	109,0	-	-	-	-	116,0
	78	21,4	107,0	-	-	-	-	114,0
	82	17,7	106,0	112,0	-	-	-	112,0
	86	14,4	104,0	112,0	-	-	-	110,0
	88	12,8	103,0	112,0	-	-	-	109,0
	90	-	100,2	112,0	-	-	-	108,0
	94	-	94,5	112,0	-	-	-	106,0
	98	-	88,7	112,0	-	-	-	105,0
	102	-	83,2	112,0	-	-	-	103,0
	106	-	77,7	112,0	-	-	-	101,0
	110	-	70,2	104,0	97,5	-	-	98,0
	112	-	65,5	100,0	97,5	-	-	97,0
	114	-	-	96,0	97,5	-	-	96,0
	118	-	-	89,0	97,5	-	-	94,0
	122	-	-	82,5	97,5	-	-	92,0
	126	-	-	74,5	97,0	-	-	86,5
	128	-	-	69,5	94,5	-	-	83,0
	130	-	-	-	92,5	-	-	79,5
	134	-	-	-	85,5	-	-	73,0
	136	-	-	-	82,5	71,5	-	70,0
	138	-	-	-	79,5	69,5	-	67,0
	142	-	-	-	74,0	66,0	-	59,0
	146	-	-	-	-	62,0	-	51,5
	150	-	-	-	-	58,5	-	44,5
	154	-	-	-	-	55,5	-	37,3
	158	-	-	-	-	-	31,9	30,4
	162	-	-	-	-	-	29,5	23,6
	166	-	-	-	-	-	27,3	18,6
	170	-	-	-	-	-	-	14,7
	174	-	-	-	-	-	-	-

Remarks · Bemerkungen · Remarques

Main boom angle 88°, 85°, 75°, 65°, 55° and 45°; capacities for intermediate boom positions are calculated by the crane control system IC-1
 Hauptauslegerwinkel 88°, 85°, 75°, 65°, 55° und 45°; Traglasten für Zwischenstellungen des Hauptauslegers werden von der Kransteuerung IC-1 berechnet
 Jarret de flèche principale 88°, 85°, 75°, 65°, 55° et 45°; le système de commande de la grue IC-1 calcule les charges pour les positions intermédiaires de la flèche

* Main boom angle 88° · Hauptauslegerwinkel 88° · Jarret de flèche principale 88°

3

SWSL / SFSL 15° LIFTING CAPACITIES · TRAGFÄHIGKEITEN · CAPACITÉS DE LEVAGE

295 t + 60 t ZB
19-30 m
10,50 m
360°
DIN/ISO

90 m + 36 m

90 m + 48 m

m	SWSL						SFSL
	0 t		0 t - 640 t				
	85°	85°	75°	65°	55°	45°	t
20	-	375,0*	-	-	-	-	-
22	-	364,0*	-	-	-	-	-
24	-	353,0*	-	-	-	-	-
26	212,0	394,0	-	-	-	-	381,0
28	197,0	385,0	-	-	-	-	381,0
30	184,0	376,0	-	-	-	-	381,0
34	162,0	358,0	-	-	-	-	381,0
38	144,0	341,0	-	-	-	-	381,0
42	129,0	328,0	-	-	-	-	381,0
44	122,0	321,0	-	-	-	-	377,0
46	-	-	-	-	-	-	370,0
47	-	-	393,0	-	-	-	367,0
50	-	-	389,0	-	-	-	352,0
54	-	-	374,0	-	-	-	340,0
58	-	-	349,0	-	-	-	328,0
60	-	-	334,0	-	-	-	312,5
62	-	-	-	-	-	-	297,0
66	-	-	-	-	-	-	271,0
67	-	-	-	268,0	-	-	265,0
70	-	-	-	255,0	-	-	247,0
74	-	-	-	239,0	-	-	227,0
76	-	-	-	232,0	-	-	217,5
78	-	-	-	-	-	-	208,0
82	-	-	-	-	-	-	191,0
84	-	-	-	-	185,0	-	183,5
86	-	-	-	-	180,0	-	176,0
89	-	-	-	-	173,0	-	165,5
90	-	-	-	-	-	-	162,0
94	-	-	-	-	-	-	150,0
98	-	-	-	-	-	-	136,0
102	-	-	-	-	-	-	121,0
106	-	-	-	-	-	-	106,0
110	-	-	-	-	-	-	91,0

m	SWSL						SFSL
	0 t		0 t - 640 t				
	85°	85°	75°	65°	55°	45°	t
24	-	303,0*	-	-	-	-	-
26	-	295,0*	-	-	-	-	-
28	-	288,0*	-	-	-	-	-
30	171,0	316,0	-	-	-	-	309,0
34	150,0	307,0	-	-	-	-	309,0
38	133,0	296,0	-	-	-	-	309,0
42	119,0	284,0	-	-	-	-	309,0
46	107,0	272,0	-	-	-	-	309,0
50	96,5	263,0	-	-	-	-	304,0
54	87,5	254,0	321,0	-	-	-	296,0
56	83,0	249,0	317,0	-	-	-	291,0
58	-	-	313,0	-	-	-	286,0
62	-	-	303,0	-	-	-	274,0
66	-	-	293,0	-	-	-	265,0
70	-	-	263,0	-	-	-	251,0
72	-	-	249,0	-	-	-	240,5
74	-	-	-	232,0	-	-	230,0
78	-	-	-	218,0	-	-	211,0
82	-	-	-	205,0	-	-	194,0
86	-	-	-	194,0	-	-	179,0
90	-	-	-	-	-	-	165,0
94	-	-	-	-	155,0	-	152,0
98	-	-	-	-	147,0	-	141,0
100	-	-	-	-	143,0	-	135,5
102	-	-	-	-	-	-	130,0
106	-	-	-	-	-	-	119,0
110	-	-	-	-	-	108,0	106,0
113	-	-	-	-	-	104,0	96,2
114	-	-	-	-	-	-	93,0
118	-	-	-	-	-	-	80,5
122	-	-	-	-	-	-	68,0
126	-	-	-	-	-	-	-
130	-	-	-	-	-	-	-

Remarks · Bemerkungen · Remarques

Main boom angle 88°, 85°, 75°, 65°, 55° and 45°; capacities for intermediate boom positions are calculated by the crane control system IC-1
 Hauptauslegerwinkel 88°, 85°, 75°, 65°, 55° und 45°; Traglasten für Zwischenstellungen des Hauptauslegers werden von der Kransteuerung IC-1 berechnet
 Jarret de flèche principale 88°, 85°, 75°, 65°, 55° et 45°; le système de commande de la grue IC-1 calcule les charges pour les positions intermédiaires de la flèche

* Main boom angle 88° · Hauptauslegerwinkel 88° · Jarret de flèche principale 88°

SWSL / SFSL 15° LIFTING CAPACITIES · TRAGFÄHIGKEITEN · CAPACITÉS DE LEVAGE

295 t + 60 t ZB	19-30 m	10,50 m	360°	DIN/ISO
-----------------	---------	---------	------	----------------

m	SWSL						SFSL
	0 t		0 t - 640 t				
	85°	85°	75°	65°	55°	45°	t
26	-	249,0*	-	-	-	-	-
28	-	247,0*	-	-	-	-	-
30	-	242,0*	-	-	-	-	-
34	140,0	259,0	-	-	-	-	252,0
38	123,0	253,0	-	-	-	-	252,0
42	110,0	245,0	-	-	-	-	252,0
46	98,5	237,0	-	-	-	-	252,0
50	89,0	229,0	-	-	-	-	252,0
54	80,0	221,0	-	-	-	-	251,0
58	72,5	215,0	-	-	-	-	245,0
60	69,0	211,0	262,0	-	-	-	242,0
62	66,0	208,0	262,0	-	-	-	239,0
66	60,0	201,0	255,0	-	-	-	233,0
68	57,5	187,0	252,0	-	-	-	227,0
70	-	-	249,0	-	-	-	224,0
74	-	-	243,0	-	-	-	218,0
78	-	-	225,0	-	-	-	211,0
82	-	-	204,0	203,0	-	-	200,0
84	-	-	195,0	197,0	-	-	192,5
86	-	-	-	191,0	-	-	185,0
90	-	-	-	181,0	-	-	171,0
94	-	-	-	171,0	-	-	158,0
98	-	-	-	163,0	-	-	146,0
102	-	-	-	-	-	-	135,0
104	-	-	-	-	133,0	-	130,0
106	-	-	-	-	129,0	-	125,0
110	-	-	-	-	123,0	-	116,0
112	-	-	-	-	120,0	-	111,5
114	-	-	-	-	-	-	107,0
118	-	-	-	-	-	-	95,5
120	-	-	-	-	-	91,0	89,7
122	-	-	-	-	-	88,5	84,0
124	-	-	-	-	-	86,0	78,5
126	-	-	-	-	-	-	73,0
130	-	-	-	-	-	-	62,5
134	-	-	-	-	-	-	52,5
138	-	-	-	-	-	-	-

m	SWSL						SFSL
	0 t		0 t - 640 t				
	85°	85°	75°	65°	55°	45°	t
30	-	203,0*	-	-	-	-	-
34	-	198,0*	-	-	-	-	-
38	114,0	211,0	-	-	-	-	206,0
42	101,0	207,0	-	-	-	-	206,0
46	90,5	202,0	-	-	-	-	206,0
50	81,0	197,0	-	-	-	-	206,0
54	73,0	192,0	-	-	-	-	206,0
58	65,5	187,0	-	-	-	-	206,0
62	59,0	181,0	-	-	-	-	203,0
66	53,5	176,0	212,0	-	-	-	199,0
70	48,5	170,0	212,0	-	-	-	195,0
74	43,9	164,0	211,0	-	-	-	191,0
78	39,7	150,0	204,0	-	-	-	186,0
80	37,8	138,0	203,0	-	-	-	183,0
82	-	-	202,0	-	-	-	181,0
86	-	-	191,0	-	-	-	177,0
90	-	-	175,0	175,0	-	-	173,0
94	-	-	159,0	166,0	-	-	160,0
98	-	-	-	157,0	-	-	148,0
102	-	-	-	149,0	-	-	137,0
106	-	-	-	142,0	-	-	127,0
110	-	-	-	135,0	-	-	117,0
112	-	-	-	-	114,0	-	113,0
114	-	-	-	-	112,0	-	109,0
118	-	-	-	-	106,0	-	100,0
122	-	-	-	-	102,0	-	93,0
124	-	-	-	-	99,5	-	88,0
126	-	-	-	-	-	-	83,0
130	-	-	-	-	-	-	73,0
132	-	-	-	-	-	71,5	68,2
134	-	-	-	-	-	69,5	63,5
136	-	-	-	-	-	67,5	58,7
138	-	-	-	-	-	-	54,0
142	-	-	-	-	-	-	44,8
146	-	-	-	-	-	-	40,7
150	-	-	-	-	-	-	-
154	-	-	-	-	-	-	-

Remarks · Bemerkungen · Remarques

Main boom angle 88°, 85°, 75°, 65°, 55° and 45°; capacities for intermediate boom positions are calculated by the crane control system IC-1
 Hauptauslegerwinkel 88°, 85°, 75°, 65°, 55° und 45°; Traglasten für Zwischenstellungen des Hauptauslegers werden von der Kransteuerung IC-1 berechnet
 Jarret de flèche principale 88°, 85°, 75°, 65°, 55° et 45°; le système de commande de la grue IC-1 calcule les charges pour les positions intermédiaires de la flèche

* Main boom angle 88° · Hauptauslegerwinkel 88° · Jarret de flèche principale 88°

SWSL / SFSL 15° LIFTING CAPACITIES · TRAGFÄHIGKEITEN · CAPACITÉS DE LEVAGE

295 t + 60 t ZB
↔ 19-30 m
■ 10,50 m
360°
DIN/ISO

90 m + 84 m

90 m + 96 m

m	SWSL							SFSL
	0 t		0 t - 640 t					
	85°	85°	75°	65°	55°	45°	t	
34	-	166,0*	-	-	-	-	-	
38	-	161,0*	-	-	-	-	-	
42	90,5	171,0	-	-	-	-	168,0	
46	80,0	169,0	-	-	-	-	168,0	
50	71,0	165,0	-	-	-	-	168,0	
54	63,0	162,0	-	-	-	-	168,0	
58	56,0	158,0	-	-	-	-	168,0	
62	50,0	155,0	-	-	-	-	168,0	
66	44,7	151,0	-	-	-	-	167,0	
70	39,8	148,0	-	-	-	-	164,0	
72	37,5	146,0	170,0	-	-	-	162,5	
74	35,3	143,0	170,0	-	-	-	161,0	
78	31,2	139,0	170,0	-	-	-	159,0	
82	27,5	134,5	169,0	-	-	-	156,0	
84	25,8	132,0	169,0	-	-	-	155,0	
86	24,1	125,5	168,0	-	-	-	154,0	
88	22,5	119,0	166,0	-	-	-	150,0	
90	-	-	164,0	-	-	-	149,0	
94	-	-	155,0	-	-	-	146,0	
98	-	-	143,0	148,0	-	-	143,0	
102	-	-	132,0	140,0	-	-	134,0	
106	-	-	119,0	133,0	-	-	124,0	
110	-	-	-	126,0	-	-	115,0	
114	-	-	-	120,0	-	-	106,0	
118	-	-	-	114,0	-	-	98,0	
120	-	-	-	111,0	-	-	94,0	
122	-	-	-	-	92,0	-	90,0	
126	-	-	-	-	87,5	-	83,0	
130	-	-	-	-	83,5	-	75,5	
134	-	-	-	-	80,0	-	66,5	
138	-	-	-	-	-	-	58,0	
142	-	-	-	-	-	52,0	49,8	
146	-	-	-	-	-	49,4	41,6	
150	-	-	-	-	-	-	33,5	
154	-	-	-	-	-	-	28,7	
158	-	-	-	-	-	-	23,7	
162	-	-	-	-	-	-	-	
166	-	-	-	-	-	-	-	
170	-	-	-	-	-	-	-	

m	SWSL							SFSL
	0 t		0 t - 640 t					
	85°	85°	75°	65°	55°	45°	t	
38	-	135,0*	-	-	-	-	-	
42	-	132,0*	-	-	-	-	-	
46	72,0	137,0	-	-	-	-	136,0	
50	63,5	136,0	-	-	-	-	136,0	
54	56,0	134,0	-	-	-	-	136,0	
58	49,2	131,0	-	-	-	-	136,0	
62	43,3	129,0	-	-	-	-	136,0	
66	38,0	126,0	-	-	-	-	136,0	
70	33,1	124,0	-	-	-	-	136,0	
74	28,8	121,0	-	-	-	-	133,0	
78	24,9	119,0	133,0	-	-	-	131,0	
82	21,3	116,0	133,0	-	-	-	128,0	
86	18,0	112,0	133,0	-	-	-	126,0	
90	14,9	108,5	133,0	-	-	-	123,0	
94	12,1	105,0	132,0	-	-	-	120,0	
96	10,8	103,0	132,0	-	-	-	119,0	
98	-	97,2	132,0	-	-	-	118,0	
100	-	91,5	131,0	-	-	-	115,5	
102	-	-	130,0	-	-	-	114,0	
106	-	-	120,0	115,0	-	-	111,0	
110	-	-	111,0	115,0	-	-	109,0	
114	-	-	103,0	114,0	-	-	106,0	
118	-	-	92,0	109,0	-	-	99,0	
122	-	-	-	104,0	-	-	91,0	
126	-	-	-	99,0	-	-	84,0	
130	-	-	-	94,5	78,0	-	77,0	
132	-	-	-	92,5	76,0	-	74,0	
134	-	-	-	-	74,5	-	71,0	
138	-	-	-	-	70,5	-	64,0	
142	-	-	-	-	67,5	-	56,0	
146	-	-	-	-	64,5	-	48,4	
150	-	-	-	-	-	-	40,8	
152	-	-	-	-	-	39,0	37,1	
154	-	-	-	-	-	37,7	33,5	
158	-	-	-	-	-	35,2	26,2	
162	-	-	-	-	-	-	20,0	
166	-	-	-	-	-	-	15,9	
170	-	-	-	-	-	-	10,6	
174	-	-	-	-	-	-	-	

Remarks · Bemerkungen · Remarques

Main boom angle 88°, 85°, 75°, 65°, 55° and 45°; capacities for intermediate boom positions are calculated by the crane control system IC-1
 Hauptauslegerwinkel 88°, 85°, 75°, 65°, 55° und 45°; Traglasten für Zwischenstellungen des Hauptauslegers werden von der Kransteuerung IC-1 berechnet
 Jarret de flèche principale 88°, 85°, 75°, 65°, 55° et 45°; le système de commande de la grue IC-1 calcule les charges pour les positions intermédiaires de la flèche

* Main boom angle 88° · Hauptauslegerwinkel 88° · Jarret de flèche principale 88°

SWSL / SFSL 15° LIFTING CAPACITIES · TRAGFÄHIGKEITEN · CAPACITÉS DE LEVAGE

90 m + 108 m

m	SWSL						SFSL
	0 t		0 t - 640 t				t
	85°	85°	75°	65°	55°	45°	
40	-	108,0*	-	-	-	-	-
42	-	108,0*	-	-	-	-	-
46	-	106,0*	-	-	-	-	-
50	56,0	110,0	-	-	-	-	109,0
54	48,6	109,0	-	-	-	-	109,0
58	42,2	107,0	-	-	-	-	109,0
62	36,5	105,0	-	-	-	-	108,0
66	31,3	104,0	-	-	-	-	108,0
70	26,7	102,0	-	-	-	-	107,0
74	22,5	100,0	-	-	-	-	107,0
78	18,7	98,5	-	-	-	-	106,0
82	15,2	96,7	-	-	-	-	104,0
84	13,5	96,0	104,0	-	-	-	103,0
86	11,9	95,0	104,0	-	-	-	102,0
88	10,4	94,0	104,0	-	-	-	101,5
90	-	91,7	104,0	-	-	-	101,0
94	-	87,5	104,0	-	-	-	99,0
98	-	83,2	104,0	-	-	-	97,5
102	-	79,0	104,0	-	-	-	96,0
106	-	74,7	103,0	-	-	-	94,0
110	-	69,7	103,0	-	-	-	91,0
112	-	67,0	103,0	-	-	-	90,2
114	-	-	99,0	89,5	-	-	89,5
118	-	-	91,5	89,5	-	-	87,5
122	-	-	84,5	89,5	-	-	86,0
126	-	-	78,0	89,5	-	-	83,0
128	-	-	73,5	89,5	-	-	79,5
130	-	-	-	88,0	-	-	76,0
134	-	-	-	83,5	-	-	69,5
138	-	-	-	79,5	-	-	63,5
140	-	-	-	77,5	62,0	-	60,7
142	-	-	-	76,0	60,5	-	58,0
144	-	-	-	74,5	59,0	-	54,5
146	-	-	-	-	57,5	-	51,0
150	-	-	-	-	54,5	-	44,0
154	-	-	-	-	51,5	-	37,1
158	-	-	-	-	48,8	-	30,4
162	-	-	-	-	-	25,2	23,8
166	-	-	-	-	-	23,0	17,4
170	-	-	-	-	-	21,0	11,1
174	-	-	-	-	-	-	-

96 m + 36 m

m	SWSL						SFSL
	0 t		0 t - 640 t				t
	85°	85°	75°	65°	55°	45°	
20	-	342,0*	-	-	-	-	-
22	-	333,0*	-	-	-	-	-
24	-	323,0*	-	-	-	-	-
26	202,0	355,0	-	-	-	-	346,0
28	188,0	351,0	-	-	-	-	346,0
30	176,0	343,0	-	-	-	-	346,0
34	155,0	326,0	-	-	-	-	346,0
38	137,0	310,0	-	-	-	-	346,0
42	123,0	299,0	-	-	-	-	346,0
46	111,0	287,0	-	-	-	-	340,0
48	-	-	361,0	-	-	-	334,0
50	-	-	357,0	-	-	-	329,0
54	-	-	347,0	-	-	-	313,0
58	-	-	334,0	-	-	-	302,0
62	-	-	318,0	-	-	-	291,0
66	-	-	-	-	-	-	266,0
69	-	-	-	251,0	-	-	248,0
70	-	-	-	247,0	-	-	242,0
74	-	-	-	231,0	-	-	222,0
78	-	-	-	217,0	-	-	203,0
82	-	-	-	-	-	-	186,0
86	-	-	-	-	-	-	171,0
88	-	-	-	-	166,0	-	164,0
90	-	-	-	-	162,0	-	157,0
93	-	-	-	-	156,0	-	148,0
94	-	-	-	-	-	-	145,0
98	-	-	-	-	-	-	133,0
102	-	-	-	-	-	-	122,0
104	-	-	-	-	-	117,0	115,0
106	-	-	-	-	-	114,0	108,0
110	-	-	-	-	-	-	94,0
114	-	-	-	-	-	-	80,5
118	-	-	-	-	-	-	67,5

Remarks · Bemerkungen · Remarques

Main boom angle 88°, 85°, 75°, 65°, 55° and 45°; capacities for intermediate boom positions are calculated by the crane control system IC-1
 Hauptauslegerwinkel 88°, 85°, 75°, 65°, 55° und 45°; Traglasten für Zwischenstellungen des Hauptauslegers werden von der Kransteuerung IC-1 berechnet
 Jarret de flèche principale 88°, 85°, 75°, 65°, 55° et 45°; le système de commande de la grue IC-1 calcule les charges pour les positions intermédiaires de la flèche

* Main boom angle 88° · Hauptauslegerwinkel 88° · Jarret de flèche principale 88°

SWSL / SFSL15° LIFTING CAPACITIES · TRAGFÄHIGKEITEN · CAPACITÉS DE LEVAGE

295 t + 60 t ZB
19-30 m
10,50 m
360°
DIN/ISO

96 m + 48 m

96 m + 60 m

m	SWSL							SFSL
	0 t		0 t - 640 t					t
	85°	85°	75°	65°	55°	45°		
24	-	277,0*	-	-	-	-	-	
26	-	270,0*	-	-	-	-	-	
28	-	263,0*	-	-	-	-	-	
30	163,0	290,0	-	-	-	-	281,0	
34	143,0	282,0	-	-	-	-	281,0	
38	127,0	270,0	-	-	-	-	281,0	
42	113,0	259,0	-	-	-	-	281,0	
46	101,0	248,0	-	-	-	-	281,0	
50	92,0	240,0	-	-	-	-	280,0	
54	83,5	231,0	292,0	-	-	-	272,0	
56	79,5	227,0	292,0	-	-	-	268,0	
58	-	-	291,0	-	-	-	264,0	
62	-	-	279,0	-	-	-	254,0	
66	-	-	272,0	-	-	-	245,0	
70	-	-	264,0	-	-	-	237,0	
74	-	-	245,0	-	-	-	225,0	
77	-	-	-	214,0	-	-	211,5	
78	-	-	-	211,0	-	-	207,0	
82	-	-	-	198,0	-	-	190,0	
86	-	-	-	187,0	-	-	174,0	
90	-	-	-	177,0	-	-	160,0	
94	-	-	-	-	-	-	147,0	
97	-	-	-	-	140,0	-	138,7	
98	-	-	-	-	139,0	-	136,0	
102	-	-	-	-	132,0	-	125,0	
104	-	-	-	-	129,0	-	120,0	
106	-	-	-	-	-	-	115,0	
110	-	-	-	-	-	-	106,0	
114	-	-	-	-	-	95,5	94,0	
117	-	-	-	-	-	92,0	85,0	
118	-	-	-	-	-	-	82,0	
122	-	-	-	-	-	-	70,5	
126	-	-	-	-	-	-	59,0	
130	-	-	-	-	-	-	51,0	
134	-	-	-	-	-	-	-	
138	-	-	-	-	-	-	-	
142	-	-	-	-	-	-	-	

m	SWSL							SFSL
	0 t		0 t - 640 t					t
	85°	85°	75°	65°	55°	45°		
26	-	229,0*	-	-	-	-	-	
28	-	226,0*	-	-	-	-	-	
30	-	222,0*	-	-	-	-	-	
34	133,0	235,0	-	-	-	-	231,0	
38	117,0	232,0	-	-	-	-	231,0	
42	104,0	225,0	-	-	-	-	231,0	
46	93,5	217,0	-	-	-	-	231,0	
50	84,0	210,0	-	-	-	-	231,0	
54	76,0	202,0	-	-	-	-	231,0	
58	68,5	196,0	-	-	-	-	227,0	
60	65,5	193,0	237,0	-	-	-	224,0	
62	62,5	190,0	237,0	-	-	-	221,0	
66	56,5	184,0	235,0	-	-	-	216,0	
68	54,0	181,0	234,0	-	-	-	213,5	
70	-	-	231,0	-	-	-	211,0	
74	-	-	223,0	-	-	-	203,0	
78	-	-	219,0	-	-	-	198,0	
82	-	-	211,0	-	-	-	192,0	
84	-	-	202,0	-	-	-	186,5	
86	-	-	-	184,0	-	-	181,0	
90	-	-	-	174,0	-	-	166,0	
94	-	-	-	165,0	-	-	153,0	
98	-	-	-	156,0	-	-	141,0	
100	-	-	-	152,0	-	-	135,5	
102	-	-	-	-	-	-	130,0	
106	-	-	-	-	122,0	-	120,0	
110	-	-	-	-	116,0	-	111,0	
114	-	-	-	-	111,0	-	102,0	
116	-	-	-	-	108,0	-	98,2	
118	-	-	-	-	-	-	94,5	
122	-	-	-	-	-	-	84,5	
126	-	-	-	-	-	-	74,0	
128	-	-	-	-	-	-	68,7	
130	-	-	-	-	-	-	63,5	
134	-	-	-	-	-	-	53,5	
138	-	-	-	-	-	-	44,6	
142	-	-	-	-	-	-	-	

Remarks · Bemerkungen · Remarques

Main boom angle 88°, 85°, 75°, 65°, 55° and 45°; capacities for intermediate boom positions are calculated by the crane control system IC-1
 Hauptauslegerwinkel 88°, 85°, 75°, 65°, 55° und 45°; Traglasten für Zwischenstellungen des Hauptauslegers werden von der Kransteuerung IC-1 berechnet
 Jarret de flèche principale 88°, 85°, 75°, 65°, 55° et 45°; le système de commande de la grue IC-1 calcule les charges pour les positions intermédiaires de la flèche

* Main boom angle 88° · Hauptauslegerwinkel 88° · Jarret de flèche principale 88°

SWSL / SFSL 15° LIFTING CAPACITIES · TRAGFÄHIGKEITEN · CAPACITÉS DE LEVAGE

295 t + 60 t ZB 19-30 m 10,50 m 360° DIN/ISO

96 m + 72 m

96 m + 84 m

m	SWSL						SFSL
	0 t		0 t - 640 t				
	85°	85°	75°	65°	55°	45°	t
30	-	187,0*	-	-	-	-	-
34	-	182,0*	-	-	-	-	-
38	-	176,0*	-	-	-	-	-
40	102,0	192,0	-	-	-	-	189,0
42	96,0	190,0	-	-	-	-	189,0
46	85,5	185,0	-	-	-	-	189,0
50	76,5	180,0	-	-	-	-	189,0
54	68,5	175,0	-	-	-	-	189,0
58	61,5	170,0	-	-	-	-	189,0
62	55,5	165,0	-	-	-	-	187,0
66	50,0	160,0	192,0	-	-	-	184,0
70	45,3	156,0	192,0	-	-	-	181,0
74	40,8	151,0	191,0	-	-	-	177,0
78	36,8	146,0	189,0	-	-	-	174,0
80	35,0	141,0	188,0	-	-	-	170,0
82	-	-	186,0	-	-	-	168,0
86	-	-	181,0	-	-	-	164,0
90	-	-	178,0	-	-	-	161,0
92	-	-	173,0	164,0	-	-	158,5
94	-	-	166,0	160,0	-	-	156,0
96	-	-	156,0	155,0	-	-	150,0
98	-	-	-	151,0	-	-	144,0
102	-	-	-	143,0	-	-	133,0
106	-	-	-	136,0	-	-	122,0
110	-	-	-	130,0	-	-	113,0
112	-	-	-	127,0	-	-	108,5
114	-	-	-	-	-	-	104,0
116	-	-	-	-	102,0	-	100,2
118	-	-	-	-	100,0	-	96,5
122	-	-	-	-	95,0	-	88,5
126	-	-	-	-	91,0	-	81,5
130	-	-	-	-	-	-	72,5
134	-	-	-	-	-	-	63,5
136	-	-	-	-	-	62,0	59,0
138	-	-	-	-	-	60,0	54,5
140	-	-	-	-	-	58,5	50,1
142	-	-	-	-	-	-	45,8
146	-	-	-	-	-	-	37,2
150	-	-	-	-	-	-	31,7
154	-	-	-	-	-	-	-
158	-	-	-	-	-	-	-

m	SWSL						SFSL
	0 t		0 t - 640 t				
	85°	85°	75°	65°	55°	45°	t
34	-	151,0*	-	-	-	-	-
38	-	148,0*	-	-	-	-	-
42	-	144,0*	-	-	-	-	-
44	80,0	156,0	-	-	-	-	154,0
46	75,0	155,0	-	-	-	-	154,0
50	66,5	151,0	-	-	-	-	154,0
54	59,0	148,0	-	-	-	-	154,0
58	52,5	144,0	-	-	-	-	154,0
62	46,5	141,0	-	-	-	-	154,0
66	41,3	137,0	-	-	-	-	153,0
70	36,5	134,0	-	-	-	-	151,0
72	34,3	132,0	154,0	-	-	-	150,0
74	32,2	130,0	154,0	-	-	-	149,0
78	28,3	127,0	154,0	-	-	-	147,0
80	26,4	125,0	154,0	-	-	-	145,5
82	24,7	123,0	154,0	-	-	-	144,0
86	21,4	119,0	152,0	-	-	-	142,0
90	18,4	110,5	151,0	-	-	-	137,0
92	17,0	104,0	150,0	-	-	-	136,0
94	-	-	147,0	-	-	-	135,0
98	-	-	145,0	-	-	-	132,0
100	-	-	141,0	127,0	-	-	131,0
102	-	-	136,0	127,0	-	-	130,0
106	-	-	125,0	126,0	-	-	120,0
108	-	-	117,0	123,0	-	-	115,0
110	-	-	-	120,0	-	-	110,0
114	-	-	-	114,0	-	-	102,0
118	-	-	-	109,0	-	-	93,5
122	-	-	-	104,0	-	-	86,0
124	-	-	-	101,0	-	-	82,5
126	-	-	-	-	81,0	-	79,0
130	-	-	-	-	77,0	-	72,0
134	-	-	-	-	73,5	-	65,5
138	-	-	-	-	70,5	-	57,0
142	-	-	-	-	-	-	49,2
146	-	-	-	-	-	43,7	41,3
150	-	-	-	-	-	41,0	33,6
154	-	-	-	-	-	-	26,0
158	-	-	-	-	-	-	19,1
162	-	-	-	-	-	-	14,9
166	-	-	-	-	-	-	-

Remarks · Bemerkungen · Remarques

Main boom angle 88°, 85°, 75°, 65°, 55° and 45°; capacities for intermediate boom positions are calculated by the crane control system IC-1
 Hauptauslegerwinkel 88°, 85°, 75°, 65°, 55° und 45°; Traglasten für Zwischenstellungen des Hauptauslegers werden von der Kransteuerung IC-1 berechnet
 Jarret de flèche principale 88°, 85°, 75°, 65°, 55° et 45°; le système de commande de la grue IC-1 calcule les charges pour les positions intermédiaires de la flèche

* Main boom angle 88° · Hauptauslegerwinkel 88° · Jarret de flèche principale 88°

SWSL / SFSL 15° LIFTING CAPACITIES · TRAGFÄHIGKEITEN · CAPACITÉS DE LEVAGE

295 t + 60 t ZB
↔ 19-30 m
■ 10,50 m
360°
DIN/ISO

96 m + 96 m

m	SWSL						SFSL
	0 t		0 t - 640 t				t
	85°	85°	75°	65°	55°	45°	
38	-	124,0*	-	-	-	-	-
42	-	121,0*	-	-	-	-	-
46	-	118,0*	-	-	-	-	-
48	63,0	125,0	-	-	-	-	124,0
50	59,0	125,0	-	-	-	-	124,0
54	51,5	123,0	-	-	-	-	124,0
58	45,3	120,0	-	-	-	-	124,0
62	39,6	117,0	-	-	-	-	124,0
66	34,5	115,0	-	-	-	-	124,0
70	29,9	113,0	-	-	-	-	124,0
74	25,7	110,0	-	-	-	-	123,0
78	21,9	108,0	121,0	-	-	-	121,0
82	18,5	105,5	121,0	-	-	-	118,0
86	15,3	102,5	121,0	-	-	-	116,0
90	12,4	99,5	121,0	-	-	-	114,0
92	11,0	98,0	121,0	-	-	-	113,0
94	-	96,5	120,0	-	-	-	112,0
98	-	93,5	119,0	-	-	-	109,0
100	-	92,0	119,0	-	-	-	107,5
102	-	-	118,0	-	-	-	106,0
106	-	-	118,0	-	-	-	103,0
108	-	-	117,0	105,0	-	-	102,0
110	-	-	114,0	105,0	-	-	101,0
114	-	-	106,0	105,0	-	-	98,5
118	-	-	96,5	104,0	-	-	95,0
120	-	-	90,5	101,0	-	-	91,0
122	-	-	-	99,0	-	-	87,0
126	-	-	-	94,0	-	-	80,0
130	-	-	-	89,5	-	-	73,0
134	-	-	-	85,5	68,0	-	66,5
138	-	-	-	-	64,5	-	60,5
142	-	-	-	-	61,5	-	54,5
146	-	-	-	-	58,5	-	47,2
150	-	-	-	-	55,5	-	39,9
154	-	-	-	-	-	-	32,8
156	-	-	-	-	-	31,1	29,3
158	-	-	-	-	-	29,9	25,8
162	-	-	-	-	-	27,6	19,0
166	-	-	-	-	-	-	12,3
170	-	-	-	-	-	-	-
174	-	-	-	-	-	-	-

96 m + 108 m

m	SWSL						SFSL
	0 t		0 t - 640 t				t
	85°	85°	75°	65°	55°	45°	
42	-	99,0*	-	-	-	-	-
46	-	97,0*	-	-	-	-	-
50	-	95,0*	-	-	-	-	-
52	47,8	100,0	-	-	-	-	-
54	44,5	100,0	-	-	-	-	100,0
58	38,3	98,5	-	-	-	-	100,0
62	32,8	97,0	-	-	-	-	99,5
66	27,9	95,0	-	-	-	-	99,0
68	25,6	94,0	-	-	-	-	98,7
70	23,4	93,0	-	-	-	-	98,5
74	19,4	91,5	-	-	-	-	98,0
78	15,7	89,5	-	-	-	-	97,5
82	12,4	87,7	-	-	-	-	96,0
84	10,8	87,0	95,0	-	-	-	95,2
86	-	86,0	95,0	-	-	-	94,5
90	-	83,5	95,0	-	-	-	93,0
94	-	80,5	95,0	-	-	-	91,5
98	-	77,2	95,0	-	-	-	90,0
102	-	74,0	94,5	-	-	-	88,5
106	-	71,0	94,5	-	-	-	87,0
110	-	67,7	94,0	-	-	-	85,5
112	-	66,0	94,0	-	-	-	83,0
114	-	-	93,5	-	-	-	82,0
116	-	-	92,5	81,5	-	-	81,2
118	-	-	91,0	81,5	-	-	80,5
122	-	-	87,0	81,5	-	-	79,0
126	-	-	80,5	81,5	-	-	77,5
130	-	-	72,0	81,5	-	-	72,0
134	-	-	-	79,0	-	-	65,5
138	-	-	-	75,0	-	-	59,5
142	-	-	-	71,5	-	-	54,0
144	-	-	-	69,5	53,5	-	51,6
146	-	-	-	68,0	52,0	-	49,2
150	-	-	-	-	49,8	-	42,3
154	-	-	-	-	46,8	-	35,6
158	-	-	-	-	43,9	-	29,0
160	-	-	-	-	42,6	-	25,8
162	-	-	-	-	-	-	22,7
166	-	-	-	-	-	17,8	16,5
170	-	-	-	-	-	15,8	10,5
174	-	-	-	-	-	14,0	-

Remarks · Bemerkungen · Remarques

Main boom angle 88°, 85°, 75°, 65°, 55° and 45°; capacities for intermediate boom positions are calculated by the crane control system IC-1
 Hauptauslegerwinkel 88°, 85°, 75°, 65°, 55° und 45°; Traglasten für Zwischenstellungen des Hauptauslegers werden von der Kransteuerung IC-1 berechnet
 Jarret de flèche principale 88°, 85°, 75°, 65°, 55° et 45°; le système de commande de la grue IC-1 calcule les charges pour les positions intermédiaires de la flèche

* Main boom angle 88° · Hauptauslegerwinkel 88° · Jarret de flèche principale 88°

SWSL / SFSL 15° LIFTING CAPACITIES · TRAGFÄHIGKEITEN · CAPACITÉS DE LEVAGE

295 t + 60 t ZB	19-30 m	10,50 m	360°	DIN/ISO
-----------------	---------	---------	------	----------------

102 m + 36 m

102 m + 48 m

m	SWSL						SFSL
	0 t		0 t - 640 t				t
	85°	85°	75°	65°	55°	45°	
20	-	312,0*	-	-	-	-	-
22	-	304,0*	-	-	-	-	-
24	-	295,0*	-	-	-	-	-
26	-	287,0*	-	-	-	-	-
28	180,0	321,0	-	-	-	-	314,0
30	168,0	314,0	-	-	-	-	314,0
34	148,0	298,0	-	-	-	-	314,0
38	131,0	284,0	-	-	-	-	314,0
42	118,0	273,0	-	-	-	-	314,0
46	106,0	263,0	-	-	-	-	312,0
50	-	-	322,0	-	-	-	303,0
54	-	-	316,0	-	-	-	293,0
58	-	-	303,0	-	-	-	280,0
62	-	-	294,0	-	-	-	271,0
64	-	-	290,0	-	-	-	266,5
66	-	-	-	-	-	-	262,0
70	-	-	-	-	-	-	238,0
72	-	-	-	231,0	-	-	227,5
74	-	-	-	223,0	-	-	217,0
78	-	-	-	210,0	-	-	198,0
80	-	-	-	203,0	-	-	190,0
82	-	-	-	-	-	-	182,0
86	-	-	-	-	-	-	166,0
90	-	-	-	-	-	-	153,0
91	-	-	-	-	151,0	-	149,7
94	-	-	-	-	145,0	-	140,0
96	-	-	-	-	142,0	-	134,5
98	-	-	-	-	-	-	129,0
102	-	-	-	-	-	-	118,0
106	-	-	-	-	-	-	108,0
108	-	-	-	-	-	104,0	101,7
110	-	-	-	-	-	101,0	95,5
114	-	-	-	-	-	-	83,0
118	-	-	-	-	-	-	70,5
122	-	-	-	-	-	-	58,5
126	-	-	-	-	-	-	-
130	-	-	-	-	-	-	-
134	-	-	-	-	-	-	-
138	-	-	-	-	-	-	-

m	SWSL						SFSL
	0 t		0 t - 640 t				t
	85°	85°	75°	65°	55°	45°	
24	-	253,0*	-	-	-	-	-
26	-	247,0*	-	-	-	-	-
28	-	241,0*	-	-	-	-	-
30	-	235,0*	-	-	-	-	-
32	145,0	262,0	-	-	-	-	256,0
34	136,0	257,0	-	-	-	-	256,0
38	121,0	247,0	-	-	-	-	256,0
42	108,0	237,0	-	-	-	-	256,0
46	97,0	227,0	-	-	-	-	256,0
50	87,5	219,0	-	-	-	-	256,0
54	79,0	211,0	-	-	-	-	250,0
56	75,5	208,0	262,0	-	-	-	247,0
58	72,0	204,0	262,0	-	-	-	244,0
62	-	-	258,0	-	-	-	237,0
66	-	-	245,0	-	-	-	227,0
70	-	-	239,0	-	-	-	221,0
74	-	-	234,0	-	-	-	214,0
76	-	-	231,0	-	-	-	208,0
78	-	-	-	-	-	-	202,0
79	-	-	-	200,0	-	-	197,7
82	-	-	-	191,0	-	-	185,0
86	-	-	-	180,0	-	-	170,0
90	-	-	-	170,0	-	-	156,0
92	-	-	-	166,0	-	-	149,5
94	-	-	-	-	-	-	143,0
98	-	-	-	-	-	-	131,0
100	-	-	-	-	127,0	-	126,0
102	-	-	-	-	124,0	-	121,0
106	-	-	-	-	118,0	-	111,0
108	-	-	-	-	115,0	-	106,5
110	-	-	-	-	-	-	102,0
114	-	-	-	-	-	-	93,5
118	-	-	-	-	-	-	82,5
119	-	-	-	-	-	83,0	79,7
120	-	-	-	-	-	81,5	77,0
122	-	-	-	-	-	-	71,5
126	-	-	-	-	-	-	61,0
130	-	-	-	-	-	-	50,5
134	-	-	-	-	-	-	42,7

3
Remarks · Bemerkungen · Remarques

Main boom angle 88°, 85°, 75°, 65°, 55° and 45°; capacities for intermediate boom positions are calculated by the crane control system IC-1
 Hauptauslegerwinkel 88°, 85°, 75°, 65°, 55° und 45°; Traglasten für Zwischenstellungen des Hauptauslegers werden von der Kransteuerung IC-1 berechnet
 Jarret de flèche principale 88°, 85°, 75°, 65°, 55° et 45°; le système de commande de la grue IC-1 calcule les charges pour les positions intermédiaires de la flèche

* Main boom angle 88° · Hauptauslegerwinkel 88° · Jarret de flèche principale 88°

SWSL / SFSL 15° LIFTING CAPACITIES · TRAGFÄHIGKEITEN · CAPACITÉS DE LEVAGE

295 t + 60 t ZB
19-30 m
10,50 m
360°
DIN/ISO

102 m + 60 m

102 m + 72 m

m	SWSL							SFSL
	0 t		0 t - 640 t					
	85°	85°	75°	65°	55°	45°	t	
28	-	207,0*	-	-	-	-	-	
30	-	203,0*	-	-	-	-	-	
34	-	194,0*	-	-	-	-	-	
36	118,0	215,0	-	-	-	-	211,0	
38	111,0	212,0	-	-	-	-	211,0	
42	99,5	205,0	-	-	-	-	211,0	
46	89,0	198,0	-	-	-	-	211,0	
50	79,5	191,0	-	-	-	-	211,0	
54	72,0	184,0	-	-	-	-	211,0	
58	65,0	178,0	-	-	-	-	208,0	
62	59,0	173,0	213,0	-	-	-	204,0	
66	53,5	167,0	213,0	-	-	-	200,0	
68	51,0	165,0	212,0	-	-	-	197,5	
70	-	-	210,0	-	-	-	195,0	
74	-	-	206,0	-	-	-	191,0	
78	-	-	198,0	-	-	-	183,0	
82	-	-	194,0	-	-	-	179,0	
86	-	-	189,0	-	-	-	174,0	
88	-	-	-	173,0	-	-	168,0	
90	-	-	-	168,0	-	-	162,0	
94	-	-	-	159,0	-	-	149,0	
98	-	-	-	150,0	-	-	137,0	
102	-	-	-	143,0	-	-	127,0	
104	-	-	-	139,0	-	-	121,5	
106	-	-	-	-	-	-	116,0	
110	-	-	-	-	109,0	-	107,0	
114	-	-	-	-	104,0	-	98,5	
118	-	-	-	-	99,0	-	90,5	
122	-	-	-	-	-	-	83,0	
126	-	-	-	-	-	-	74,0	
130	-	-	-	-	-	68,0	64,0	
132	-	-	-	-	-	66,0	59,2	
134	-	-	-	-	-	-	54,5	
138	-	-	-	-	-	-	45,5	
142	-	-	-	-	-	-	36,4	
146	-	-	-	-	-	-	31,1	
150	-	-	-	-	-	-	-	
154	-	-	-	-	-	-	-	
158	-	-	-	-	-	-	-	

m	SWSL							SFSL
	0 t		0 t - 640 t					
	85°	85°	75°	65°	55°	45°	t	
30	-	171,0*	-	-	-	-	-	
34	-	167,0*	-	-	-	-	-	
38	-	160,0*	-	-	-	-	-	
40	96,5	176,0	-	-	-	-	173,0	
42	91,0	174,0	-	-	-	-	173,0	
46	80,5	169,0	-	-	-	-	173,0	
50	72,0	164,0	-	-	-	-	173,0	
54	64,5	159,0	-	-	-	-	173,0	
58	58,0	154,0	-	-	-	-	173,0	
62	52,0	150,0	-	-	-	-	172,0	
66	46,9	145,0	-	-	-	-	170,0	
68	44,4	143,0	173,0	-	-	-	168,5	
70	42,1	141,0	173,0	-	-	-	167,0	
74	37,8	137,0	172,0	-	-	-	164,0	
78	33,9	133,0	171,0	-	-	-	161,0	
80	32,1	131,0	169,0	-	-	-	159,5	
82	-	-	168,0	-	-	-	158,0	
86	-	-	166,0	-	-	-	152,0	
90	-	-	161,0	-	-	-	149,0	
94	-	-	157,0	-	-	-	145,0	
96	-	-	156,0	149,0	-	-	142,5	
98	-	-	154,0	145,0	-	-	140,0	
102	-	-	-	138,0	-	-	129,0	
106	-	-	-	131,0	-	-	119,0	
110	-	-	-	124,0	-	-	109,0	
114	-	-	-	118,0	-	-	100,0	
118	-	-	-	-	-	-	92,5	
120	-	-	-	-	91,0	-	88,7	
122	-	-	-	-	88,5	-	85,0	
126	-	-	-	-	84,5	-	77,5	
130	-	-	-	-	81,0	-	71,0	
134	-	-	-	-	-	-	62,5	
138	-	-	-	-	-	-	54,0	
140	-	-	-	-	-	53,0	50,0	
142	-	-	-	-	-	51,5	46,0	
144	-	-	-	-	-	50,0	41,9	
146	-	-	-	-	-	-	37,8	
150	-	-	-	-	-	-	29,7	
154	-	-	-	-	-	-	22,6	

Remarks · Bemerkungen · Remarques

Main boom angle 88°, 85°, 75°, 65°, 55° and 45°; capacities for intermediate boom positions are calculated by the crane control system IC-1
 Hauptauslegerwinkel 88°, 85°, 75°, 65°, 55° und 45°; Traglasten für Zwischenstellungen des Hauptauslegers werden von der Kransteuerung IC-1 berechnet
 Jarret de flèche principale 88°, 85°, 75°, 65°, 55° et 45°; le système de commande de la grue IC-1 calcule les charges pour les positions intermédiaires de la flèche

* Main boom angle 88° · Hauptauslegerwinkel 88° · Jarret de flèche principale 88°

SWSL / SFSL 15° LIFTING CAPACITIES · TRAGFÄHIGKEITEN · CAPACITÉS DE LEVAGE

295 t + 60 t ZB 19-30 m 10,50 m 360° DIN/ISO

102 m + 84 m

102 m + 96 m

m	SWSL						SFSL
	0 t		0 t - 640 t				
	85°	85°	75°	65°	55°	45°	t
34	-	139,0*	-	-	-	-	-
38	-	136,0*	-	-	-	-	-
42	-	132,0*	-	-	-	-	-
44	75,0	142,0	-	-	-	-	140,0
46	70,5	141,0	-	-	-	-	140,0
50	62,0	138,0	-	-	-	-	140,0
54	55,0	134,0	-	-	-	-	140,0
58	48,6	131,0	-	-	-	-	140,0
62	43,0	127,0	-	-	-	-	140,0
66	37,9	124,0	-	-	-	-	140,0
70	33,3	120,0	-	-	-	-	138,0
74	29,2	117,0	137,0	-	-	-	135,0
78	25,4	114,0	137,0	-	-	-	132,0
80	23,7	113,0	137,0	-	-	-	130,5
82	22,0	111,5	136,0	-	-	-	129,0
86	18,9	108,5	135,0	-	-	-	126,0
90	16,0	105,5	133,0	-	-	-	124,0
92	14,6	104,0	132,0	-	-	-	122,5
94	-	-	131,0	-	-	-	121,0
98	-	-	130,0	-	-	-	116,0
102	-	-	128,0	116,0	-	-	113,0
106	-	-	123,0	116,0	-	-	110,0
110	-	-	115,0	115,0	-	-	107,0
114	-	-	-	109,0	-	-	98,0
118	-	-	-	104,0	-	-	90,0
122	-	-	-	99,0	-	-	82,0
126	-	-	-	94,5	-	-	75,0
128	-	-	-	-	73,0	-	71,5
130	-	-	-	-	71,0	-	68,0
134	-	-	-	-	67,5	-	62,0
138	-	-	-	-	64,0	-	55,5
142	-	-	-	-	61,5	-	48,0
146	-	-	-	-	-	-	40,4
150	-	-	-	-	-	35,3	33,0
154	-	-	-	-	-	32,9	25,8
156	-	-	-	-	-	31,8	22,2
158	-	-	-	-	-	-	18,7
162	-	-	-	-	-	-	11,7
166	-	-	-	-	-	-	-
170	-	-	-	-	-	-	-
174	-	-	-	-	-	-	-

m	SWSL						SFSL
	0 t		0 t - 640 t				
	85°	85°	75°	65°	55°	45°	t
38	-	113,0*	-	-	-	-	-
42	-	111,0*	-	-	-	-	-
46	-	108,0*	-	-	-	-	-
48	58,0	115,0	-	-	-	-	114,0
50	54,5	114,0	-	-	-	-	114,0
54	47,6	112,0	-	-	-	-	114,0
58	41,5	109,0	-	-	-	-	114,0
62	36,0	107,0	-	-	-	-	113,0
66	31,2	104,0	-	-	-	-	113,0
70	26,7	102,0	-	-	-	-	113,0
72	24,7	101,0	-	-	-	-	112,5
74	22,7	99,5	-	-	-	-	112,0
78	19,1	97,0	-	-	-	-	110,0
80	17,4	96,0	109,0	-	-	-	109,0
82	15,8	94,7	109,0	-	-	-	108,0
86	12,7	92,2	109,0	-	-	-	106,0
88	11,2	91,0	109,0	-	-	-	105,0
90	-	89,7	109,0	-	-	-	104,0
94	-	87,2	108,0	-	-	-	102,0
98	-	85,0	107,0	-	-	-	100,0
102	-	82,7	106,0	-	-	-	98,5
104	-	81,5	106,0	-	-	-	95,7
106	-	-	105,0	-	-	-	94,5
110	-	-	104,0	94,5	-	-	92,5
114	-	-	103,0	94,5	-	-	90,5
118	-	-	99,5	94,5	-	-	88,5
120	-	-	95,5	94,5	-	-	86,0
122	-	-	-	94,0	-	-	83,5
126	-	-	-	89,0	-	-	76,5
130	-	-	-	85,0	-	-	69,5
134	-	-	-	81,0	-	-	63,0
138	-	-	-	77,0	59,0	-	57,0
142	-	-	-	-	55,5	-	52,5
146	-	-	-	-	53,0	-	45,5
150	-	-	-	-	50,5	-	38,4
152	-	-	-	-	49,8	-	35,0
154	-	-	-	-	-	-	31,6
158	-	-	-	-	-	-	24,9
160	-	-	-	-	-	23,3	21,6
162	-	-	-	-	-	22,2	18,4
166	-	-	-	-	-	20,2	12,0

Remarks · Bemerkungen · Remarques

Main boom angle 88°, 85°, 75°, 65°, 55° and 45°; capacities for intermediate boom positions are calculated by the crane control system IC-1
 Hauptauslegerwinkel 88°, 85°, 75°, 65°, 55° und 45°; Traglasten für Zwischenstellungen des Hauptauslegers werden von der Kransteuerung IC-1 berechnet
 Jarret de flèche principale 88°, 85°, 75°, 65°, 55° et 45°; le système de commande de la grue IC-1 calcule les charges pour les positions intermédiaires de la flèche

* Main boom angle 88° · Hauptauslegerwinkel 88° · Jarret de flèche principale 88°

SWSL / SFSL 15° LIFTING CAPACITIES · TRAGFÄHIGKEITEN · CAPACITÉS DE LEVAGE

295 t + 60 t ZB
↔ 19-30 m
■ 10,50 m
360°
DIN/ISO

102 m + 108 m

108 m + 36 m

m	SWSL						SFSL
	0 t		0 t - 640 t				
	85°	85°	75°	65°	55°	45°	t
42	-	90,5*	-	-	-	-	-
46	-	88,5*	-	-	-	-	-
50	-	86,5*	-	-	-	-	-
52	43,6	91,5	-	-	-	-	-
54	40,4	91,5	-	-	-	-	91,0
58	34,4	89,5	-	-	-	-	91,0
62	29,2	88,0	-	-	-	-	91,0
64	26,8	87,0	-	-	-	-	90,7
66	24,5	86,0	-	-	-	-	90,5
70	20,3	84,5	-	-	-	-	90,0
74	16,4	82,5	-	-	-	-	89,5
78	12,8	80,5	-	-	-	-	88,5
80	11,2	80,0	-	-	-	-	88,0
82	-	79,0	-	-	-	-	87,5
86	-	77,0	85,5	-	-	-	86,0
90	-	75,0	85,5	-	-	-	84,5
94	-	73,0	85,5	-	-	-	83,0
98	-	70,7	85,5	-	-	-	82,0
102	-	68,5	85,5	-	-	-	80,5
106	-	66,5	84,5	-	-	-	79,0
110	-	64,2	84,0	-	-	-	77,5
112	-	63,0	83,5	-	-	-	76,5
114	-	-	83,5	-	-	-	75,5
118	-	-	82,5	72,5	-	-	73,0
122	-	-	81,5	72,5	-	-	72,0
126	-	-	80,0	72,5	-	-	70,5
130	-	-	76,0	72,5	-	-	68,5
132	-	-	71,0	72,5	-	-	65,2
134	-	-	-	72,5	-	-	62,0
138	-	-	-	70,5	-	-	56,0
142	-	-	-	67,0	-	-	51,5
146	-	-	-	63,5	47,9	-	46,9
148	-	-	-	62,0	46,3	-	43,5
150	-	-	-	-	44,7	-	40,2
154	-	-	-	-	41,7	-	33,6
158	-	-	-	-	38,9	-	27,3
162	-	-	-	-	36,3	-	21,2
164	-	-	-	-	35,1	-	18,2
166	-	-	-	-	-	-	15,2

m	SWSL						SFSL
	0 t		0 t - 640 t				
	85°	85°	75°	65°	55°	45°	t
20	-	283,0*	-	-	-	-	-
22	-	276,0*	-	-	-	-	-
24	-	269,0*	-	-	-	-	-
26	-	262,0*	-	-	-	-	-
28	171,0	291,0	-	-	-	-	285,0
30	159,0	285,0	-	-	-	-	285,0
34	140,0	272,0	-	-	-	-	285,0
38	125,0	260,0	-	-	-	-	285,0
42	112,0	249,0	-	-	-	-	285,0
46	101,0	240,0	-	-	-	-	285,0
50	-	-	-	-	-	-	276,0
52	-	-	288,0	-	-	-	272,0
54	-	-	288,0	-	-	-	268,0
58	-	-	280,0	-	-	-	260,0
62	-	-	266,0	-	-	-	249,0
66	-	-	259,0	-	-	-	240,0
70	-	-	-	-	-	-	232,0
74	-	-	-	215,0	-	-	212,0
78	-	-	-	201,0	-	-	193,0
82	-	-	-	190,0	-	-	177,0
86	-	-	-	-	-	-	161,0
90	-	-	-	-	-	-	147,0
94	-	-	-	-	-	-	135,0
95	-	-	-	-	134,0	-	132,0
98	-	-	-	-	129,0	-	123,0
100	-	-	-	-	126,0	-	118,0
102	-	-	-	-	-	-	113,0
106	-	-	-	-	-	-	103,0
110	-	-	-	-	-	-	94,5
112	-	-	-	-	-	90,5	88,5
114	-	-	-	-	-	88,0	82,5
118	-	-	-	-	-	-	71,0
122	-	-	-	-	-	-	60,0
126	-	-	-	-	-	-	49,0
130	-	-	-	-	-	-	-

Remarks · Bemerkungen · Remarques

Main boom angle 88°, 85°, 75°, 65°, 55° and 45°; capacities for intermediate boom positions are calculated by the crane control system IC-1
 Hauptauslegerwinkel 88°, 85°, 75°, 65°, 55° und 45°; Traglasten für Zwischenstellungen des Hauptauslegers werden von der Kransteuerung IC-1 berechnet
 Jarret de flèche principale 88°, 85°, 75°, 65°, 55° et 45°; le système de commande de la grue IC-1 calcule les charges pour les positions intermédiaires de la flèche

* Main boom angle 88° · Hauptauslegerwinkel 88° · Jarret de flèche principale 88°

SWSL / SFSL 15° LIFTING CAPACITIES · TRAGFÄHIGKEITEN · CAPACITÉS DE LEVAGE

295 t + 60 t ZB	19-30 m	10,50 m	360°	DIN/ISO
-----------------	---------	---------	------	----------------

m	SWSL						SFSL
	0 t		0 t - 640 t				t
	85°	85°	75°	65°	55°	45°	
24	-	230,0*	-	-	-	-	-
26	-	225,0*	-	-	-	-	-
28	-	220,0*	-	-	-	-	-
30	-	214,0*	-	-	-	-	-
32	137,0	237,0	-	-	-	-	233,0
34	129,0	233,0	-	-	-	-	233,0
38	114,0	224,0	-	-	-	-	233,0
42	102,0	215,0	-	-	-	-	233,0
46	91,5	206,0	-	-	-	-	233,0
50	82,5	199,0	-	-	-	-	233,0
54	74,5	192,0	-	-	-	-	229,0
58	68,0	185,0	234,0	-	-	-	224,0
62	-	-	232,0	-	-	-	218,0
66	-	-	226,0	-	-	-	213,0
70	-	-	220,0	-	-	-	204,0
74	-	-	210,0	-	-	-	198,0
76	-	-	207,0	-	-	-	195,5
78	-	-	-	-	-	-	193,0
82	-	-	-	183,0	-	-	181,0
86	-	-	-	173,0	-	-	165,0
90	-	-	-	163,0	-	-	151,0
94	-	-	-	154,0	-	-	138,0
98	-	-	-	-	-	-	127,0
102	-	-	-	-	-	-	116,0
104	-	-	-	-	113,0	-	111,0
106	-	-	-	-	110,0	-	106,0
110	-	-	-	-	105,0	-	97,0
114	-	-	-	-	-	-	88,5
118	-	-	-	-	-	-	80,5
122	-	-	-	-	-	-	70,5
124	-	-	-	-	-	70,0	65,5
126	-	-	-	-	-	68,0	60,5
130	-	-	-	-	-	-	50,5
134	-	-	-	-	-	-	41,1
138	-	-	-	-	-	-	32,1
142	-	-	-	-	-	-	-
146	-	-	-	-	-	-	-

m	SWSL						SFSL
	0 t		0 t - 640 t				t
	85°	85°	75°	65°	55°	45°	
28	-	189,0*	-	-	-	-	-
30	-	185,0*	-	-	-	-	-
34	-	177,0*	-	-	-	-	-
36	112,0	194,0	-	-	-	-	191,0
38	105,0	192,0	-	-	-	-	191,0
42	93,5	186,0	-	-	-	-	191,0
46	83,5	179,0	-	-	-	-	191,0
50	75,0	172,0	-	-	-	-	191,0
54	67,5	166,0	-	-	-	-	191,0
58	61,0	161,0	-	-	-	-	190,0
62	55,0	156,0	-	-	-	-	187,0
64	52,0	153,0	192,0	-	-	-	185,0
66	49,9	151,0	192,0	-	-	-	183,0
70	45,2	146,0	189,0	-	-	-	179,0
74	-	-	185,0	-	-	-	175,0
78	-	-	180,0	-	-	-	171,0
82	-	-	176,0	-	-	-	165,0
86	-	-	170,0	-	-	-	161,0
88	-	-	167,0	-	-	-	159,0
90	-	-	-	161,0	-	-	157,0
94	-	-	-	152,0	-	-	145,0
98	-	-	-	144,0	-	-	133,0
102	-	-	-	137,0	-	-	122,0
106	-	-	-	130,0	-	-	112,0
110	-	-	-	-	-	-	103,0
114	-	-	-	-	96,5	-	94,0
118	-	-	-	-	92,0	-	86,0
122	-	-	-	-	87,5	-	78,5
126	-	-	-	-	-	-	71,5
130	-	-	-	-	-	-	62,5
134	-	-	-	-	-	57,0	53,5
136	-	-	-	-	-	55,5	49,2
138	-	-	-	-	-	-	45,0
142	-	-	-	-	-	-	36,4
146	-	-	-	-	-	-	28,0
150	-	-	-	-	-	-	20,9
154	-	-	-	-	-	-	-

3
Remarks · Bemerkungen · Remarques

Main boom angle 88°, 85°, 75°, 65°, 55° and 45°; capacities for intermediate boom positions are calculated by the crane control system IC-1
 Hauptauslegerwinkel 88°, 85°, 75°, 65°, 55° und 45°; Traglasten für Zwischenstellungen des Hauptauslegers werden von der Kransteuerung IC-1 berechnet
 Jarret de flèche principale 88°, 85°, 75°, 65°, 55° et 45°; le système de commande de la grue IC-1 calcule les charges pour les positions intermédiaires de la flèche

* Main boom angle 88° · Hauptauslegerwinkel 88° · Jarret de flèche principale 88°

SWSL / SFSL 15° LIFTING CAPACITIES · TRAGFÄHIGKEITEN · CAPACITÉS DE LEVAGE

295 t + 60 t ZB
↔ 19-30 m
■ 10,50 m
360°
DIN/ISO

108 m + 72 m

m	SWSL						SFSL
	0 t		0 t - 640 t				
	85°	85°	75°	65°	55°	45°	t
30	-	155,0*	-	-	-	-	-
34	-	151,0*	-	-	-	-	-
38	-	146,0*	-	-	-	-	-
40	90,5	159,0	-	-	-	-	156,0
42	85,0	158,0	-	-	-	-	156,0
46	75,5	153,0	-	-	-	-	156,0
50	67,5	148,0	-	-	-	-	156,0
54	60,0	143,0	-	-	-	-	156,0
58	54,0	139,0	-	-	-	-	156,0
62	48,3	134,0	-	-	-	-	156,0
66	43,3	130,0	-	-	-	-	154,0
70	38,7	126,0	156,0	-	-	-	152,0
74	34,6	123,0	155,0	-	-	-	149,0
78	30,8	119,0	153,0	-	-	-	147,0
80	29,1	118,0	152,0	-	-	-	145,5
82	-	-	151,0	-	-	-	144,0
86	-	-	148,0	-	-	-	141,0
90	-	-	145,0	-	-	-	136,0
94	-	-	142,0	-	-	-	133,0
98	-	-	139,0	126,0	-	-	130,0
100	-	-	136,0	126,0	-	-	127,5
102	-	-	-	126,0	-	-	125,0
106	-	-	-	123,0	-	-	114,0
110	-	-	-	118,0	-	-	105,0
114	-	-	-	113,0	-	-	96,5
118	-	-	-	107,0	-	-	88,0
122	-	-	-	-	81,5	-	80,5
126	-	-	-	-	77,5	-	73,5
130	-	-	-	-	74,0	-	66,5
134	-	-	-	-	71,0	-	60,0
138	-	-	-	-	-	-	52,5
142	-	-	-	-	-	-	44,5
144	-	-	-	-	-	43,3	40,6
146	-	-	-	-	-	42,0	36,7
148	-	-	-	-	-	40,7	32,9
150	-	-	-	-	-	-	29,1
154	-	-	-	-	-	-	21,5
158	-	-	-	-	-	-	14,1
162	-	-	-	-	-	-	-
166	-	-	-	-	-	-	-
170	-	-	-	-	-	-	-

108 m + 84 m

m	SWSL						SFSL
	0 t		0 t - 640 t				
	85°	85°	75°	65°	55°	45°	t
34	-	126,0*	-	-	-	-	-
38	-	124,0*	-	-	-	-	-
42	-	120,0*	-	-	-	-	-
44	69,5	129,0	-	-	-	-	127,0
46	65,0	128,0	-	-	-	-	127,0
50	57,5	125,0	-	-	-	-	127,0
54	50,5	121,0	-	-	-	-	127,0
58	44,6	118,0	-	-	-	-	127,0
62	39,2	114,0	-	-	-	-	127,0
66	34,3	111,0	-	-	-	-	127,0
70	29,9	107,0	-	-	-	-	125,0
74	26,0	104,0	-	-	-	-	123,0
76	24,1	103,0	123,0	-	-	-	121,5
78	22,3	101,0	123,0	-	-	-	120,0
82	19,1	98,5	122,0	-	-	-	118,0
86	16,0	95,7	121,0	-	-	-	116,0
90	13,3	93,0	119,0	-	-	-	113,0
92	12,0	91,5	118,0	-	-	-	112,0
94	-	-	117,0	-	-	-	111,0
98	-	-	115,0	-	-	-	107,0
102	-	-	113,0	-	-	-	103,0
106	-	-	110,0	104,0	-	-	101,0
110	-	-	108,0	104,0	-	-	98,5
114	-	-	-	103,0	-	-	94,0
118	-	-	-	98,0	-	-	85,5
122	-	-	-	93,5	-	-	78,0
126	-	-	-	89,0	-	-	70,5
128	-	-	-	87,0	-	-	67,2
130	-	-	-	-	-	-	64,0
132	-	-	-	-	62,5	-	61,0
134	-	-	-	-	61,0	-	58,0
138	-	-	-	-	57,5	-	53,0
142	-	-	-	-	55,0	-	45,6
144	-	-	-	-	54,0	-	41,9
146	-	-	-	-	-	-	38,2
150	-	-	-	-	-	-	31,1
154	-	-	-	-	-	26,3	24,2
158	-	-	-	-	-	24,2	17,4
160	-	-	-	-	-	23,2	14,1
162	-	-	-	-	-	-	10,8
166	-	-	-	-	-	-	-

Remarks · Bemerkungen · Remarques

Main boom angle 88°, 85°, 75°, 65°, 55° and 45°; capacities for intermediate boom positions are calculated by the crane control system IC-1
 Hauptauslegerwinkel 88°, 85°, 75°, 65°, 55° und 45°; Traglasten für Zwischenstellungen des Hauptauslegers werden von der Kransteuerung IC-1 berechnet
 Jarret de flèche principale 88°, 85°, 75°, 65°, 55° et 45°; le système de commande de la grue IC-1 calcule les charges pour les positions intermédiaires de la flèche

* Main boom angle 88° · Hauptauslegerwinkel 88° · Jarret de flèche principale 88°

SWSL / SFSL 15° LIFTING CAPACITIES · TRAGFÄHIGKEITEN · CAPACITÉS DE LEVAGE

295 t + 60 t ZB 19-30 m 10,50 m 360° DIN/ISO

108 m + 96 m

108 m + 108 m

m	SWSL						SFSL
	0 t		0 t - 640 t				t
	85°	85°	75°	65°	55°	45°	
38	-	102,0*	-	-	-	-	-
42	-	100,0*	-	-	-	-	-
46	-	98,0*	-	-	-	-	-
48	53,5	104,0	-	-	-	-	103,0
50	49,9	104,0	-	-	-	-	103,0
54	43,3	101,0	-	-	-	-	103,0
58	37,4	99,5	-	-	-	-	103,0
62	32,3	97,0	-	-	-	-	103,0
66	27,5	94,0	-	-	-	-	102,0
68	25,4	92,5	-	-	-	-	102,0
70	23,3	91,5	-	-	-	-	102,0
74	19,5	89,0	-	-	-	-	101,0
78	16,0	86,5	-	-	-	-	99,5
82	12,8	83,7	98,0	-	-	-	98,0
84	11,3	82,5	98,0	-	-	-	97,0
86	-	81,5	98,0	-	-	-	96,0
90	-	79,2	97,5	-	-	-	94,5
94	-	77,0	97,0	-	-	-	92,5
98	-	74,7	95,5	-	-	-	91,0
102	-	72,5	94,5	-	-	-	89,5
104	-	71,5	94,0	-	-	-	88,5
106	-	-	93,0	-	-	-	87,5
110	-	-	92,0	-	-	-	84,0
114	-	-	90,0	83,0	-	-	82,0
118	-	-	88,5	83,0	-	-	80,0
122	-	-	87,0	83,0	-	-	78,5
126	-	-	-	83,0	-	-	72,5
130	-	-	-	79,5	-	-	65,5
134	-	-	-	75,5	-	-	59,0
138	-	-	-	72,0	-	-	54,0
140	-	-	-	70,5	-	-	51,7
142	-	-	-	-	51,0	-	49,4
146	-	-	-	-	48,6	-	42,7
150	-	-	-	-	46,3	-	35,9
154	-	-	-	-	43,4	-	29,2
156	-	-	-	-	42,0	-	26,0
158	-	-	-	-	-	-	22,8
162	-	-	-	-	-	-	16,5
164	-	-	-	-	-	15,0	13,4
166	-	-	-	-	-	14,1	10,4
170	-	-	-	-	-	12,3	-

m	SWSL						SFSL
	0 t		0 t - 640 t				t
	85°	85°	75°	65°	55°	45°	
42	-	82,0*	-	-	-	-	-
46	-	80,0*	-	-	-	-	-
50	-	78,0*	-	-	-	-	-
52	39,1	82,5	-	-	-	-	-
54	36,0	82,5	-	-	-	-	82,5
58	30,4	81,0	-	-	-	-	82,5
60	27,8	80,0	-	-	-	-	82,2
62	25,4	79,5	-	-	-	-	82,0
66	20,9	77,5	-	-	-	-	81,5
70	16,8	75,5	-	-	-	-	81,0
74	13,1	73,5	-	-	-	-	80,5
76	11,4	72,5	-	-	-	-	80,0
78	-	71,5	-	-	-	-	79,5
82	-	69,7	-	-	-	-	78,5
86	-	68,0	-	-	-	-	77,0
88	-	67,0	76,5	-	-	-	76,5
90	-	66,0	76,5	-	-	-	76,0
94	-	64,2	76,5	-	-	-	74,5
98	-	62,5	76,0	-	-	-	73,0
102	-	60,7	75,5	-	-	-	72,0
106	-	59,0	75,0	-	-	-	70,5
110	-	57,2	74,0	-	-	-	69,0
114	-	55,5	73,5	-	-	-	67,5
116	-	54,5	73,0	-	-	-	65,7
118	-	-	72,5	-	-	-	65,0
120	-	-	72,0	63,5	-	-	64,2
122	-	-	71,5	63,5	-	-	63,5
126	-	-	70,5	63,5	-	-	62,0
130	-	-	69,5	63,5	-	-	60,5
134	-	-	68,0	63,5	-	-	58,5
138	-	-	-	63,5	-	-	53,0
142	-	-	-	62,0	-	-	48,7
146	-	-	-	58,5	-	-	43,6
150	-	-	-	56,0	38,7	-	37,0
154	-	-	-	-	35,8	-	30,7
158	-	-	-	-	33,1	-	24,5
162	-	-	-	-	30,6	-	18,6
166	-	-	-	-	28,3	-	12,8
168	-	-	-	-	27,2	-	-
170	-	-	-	-	-	-	-
174	-	-	-	-	-	-	-

Remarks · Bemerkungen · Remarques

Main boom angle 88°, 85°, 75°, 65°, 55° and 45°; capacities for intermediate boom positions are calculated by the crane control system IC-1
 Hauptauslegerwinkel 88°, 85°, 75°, 65°, 55° und 45°; Traglasten für Zwischenstellungen des Hauptauslegers werden von der Kransteuerung IC-1 berechnet
 Jarret de flèche principale 88°, 85°, 75°, 65°, 55° et 45°; le système de commande de la grue IC-1 calcule les charges pour les positions intermédiaires de la flèche

* Main boom angle 88° · Hauptauslegerwinkel 88° · Jarret de flèche principale 88°

3

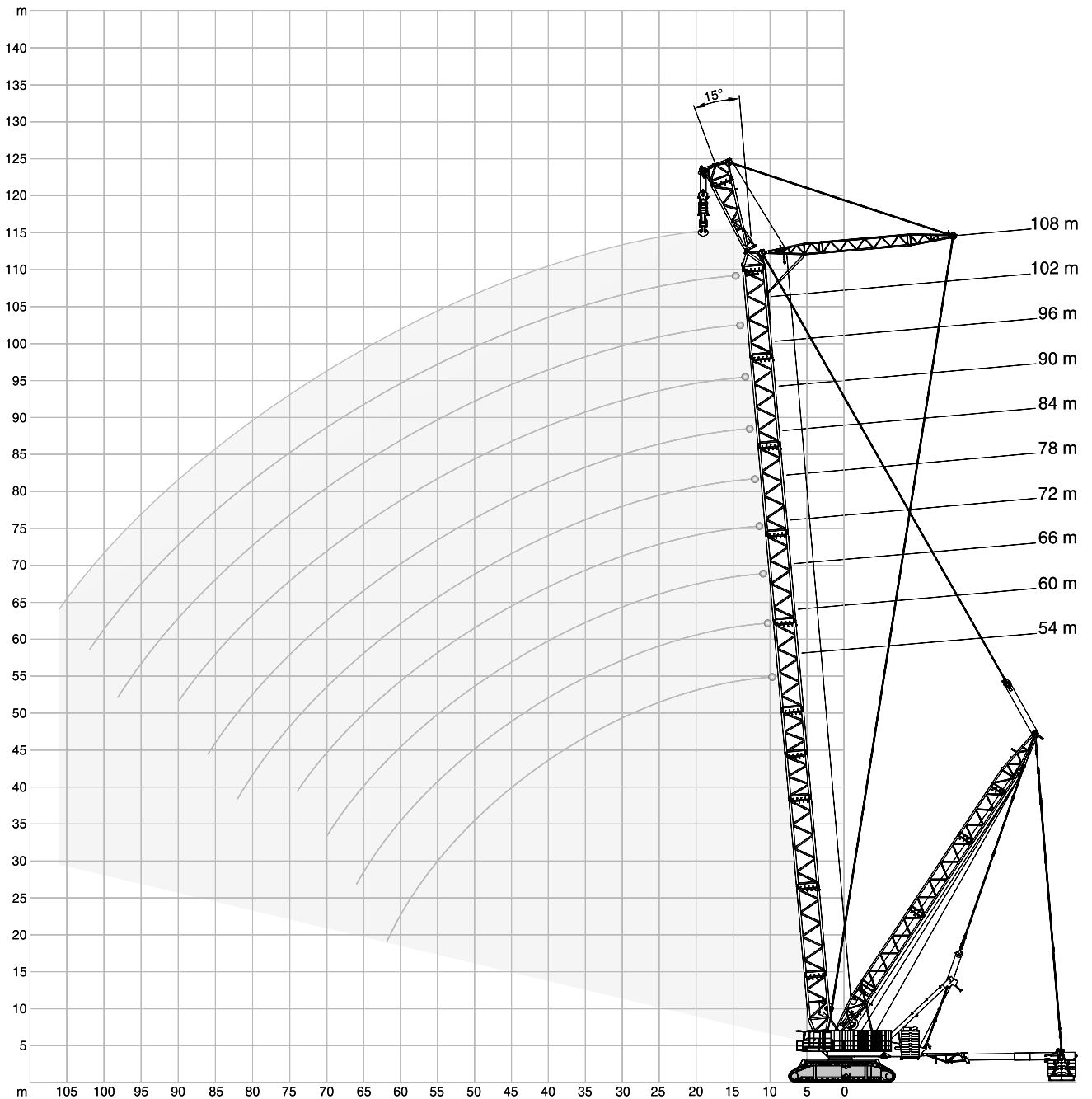

SFVL LIFTING CAPACITIES · TRAGFÄHIGKEITEN ·
CAPACITÉS DE LEVAGE

295 t + 60 t ZB 19-30 m 12 m 15° 0-640 t 10,50 m 360° DIN/ISO

	54 m	60 m	66 m	72 m	78 m	84 m	90 m	96 m	102 m	108 m	
m	t	t	t	t	t	t	t	t	t	t	m
14	1071,0	-	-	-	-	-	-	-	-	-	14
16	1007,0	983,0	972,0	876,0	793,0	-	-	-	-	-	16
18	951,0	934,0	972,0	876,0	793,0	710,0	637,0	572,0	-	-	18
20	901,0	890,0	946,0	876,0	793,0	710,0	637,0	572,0	516,0	464,0	20
22	857,0	850,0	904,0	876,0	793,0	710,0	637,0	572,0	516,0	464,0	22
24	817,0	814,0	866,0	855,0	793,0	710,0	637,0	572,0	516,0	464,0	24
26	781,0	781,0	831,0	831,0	771,0	707,0	637,0	572,0	516,0	464,0	26
28	748,0	751,0	798,0	801,0	764,0	700,0	634,0	572,0	516,0	464,0	28
30	718,0	723,0	751,0	745,0	739,0	689,0	630,0	570,0	515,0	464,0	30
34	663,0	657,0	651,0	645,0	639,0	633,0	623,0	563,0	513,0	461,0	34
38	584,0	578,0	572,0	566,0	560,0	554,0	549,0	543,0	507,0	459,0	38
42	510,0	514,0	508,0	502,0	496,0	490,0	484,0	478,0	473,0	438,0	42
46	438,0	462,0	455,0	449,0	443,0	437,0	431,0	425,0	419,0	413,0	46
50	377,0	406,0	409,0	403,0	397,0	391,0	386,0	380,0	374,0	368,0	50
54	334,0	352,0	371,0	365,0	358,0	352,0	347,0	341,0	335,0	329,0	54
58	291,0	305,0	326,0	331,0	325,0	319,0	313,0	307,0	302,0	295,0	58
62	245,0	273,0	284,0	300,0	297,0	290,0	285,0	278,0	273,0	266,0	62
66	-	237,0	246,0	263,0	272,0	265,0	259,0	253,0	247,0	241,0	66
70	-	-	225,0	229,0	242,0	243,0	237,0	231,0	225,0	219,0	70
74	-	-	-	201,0	212,0	220,0	218,0	212,0	206,0	199,0	74
78	-	-	-	-	184,0	194,0	200,0	194,0	188,0	182,0	78
82	-	-	-	-	166,0	169,0	177,0	179,0	173,0	166,0	82
86	-	-	-	-	-	147,0	155,0	159,0	159,0	152,0	86
90	-	-	-	-	-	-	134,0	139,0	142,0	139,0	90
94	-	-	-	-	-	-	-	120,0	124,0	125,0	94
98	-	-	-	-	-	-	-	105,0	108,0	109,0	98
102	-	-	-	-	-	-	-	-	91,5	94,0	102
106	-	-	-	-	-	-	-	-	-	79,5	106
110	-	-	-	-	-	-	-	-	-	-	110

TECHNICAL DESCRIPTION

CRAWLER CARRIER

	5-section carrier comprising carbody, two cross axles and two split-type crawler side frames. Carbody, cross axles and side frames are pin-connected hydraulically. Track width: 10.5 m.
Carbody	Bending- and torsion-resistant welded structure fabricated from high-strength fine grain structural steel. Quick-disconnect fittings (optional) facilitate removal of slew ring from carbody to minimise weight for transportation.
Cross axles	Bending- and torsion-resistant welded structure fabricated from high-strength fine grain structural steel incl. hydraulic jack legs.
Crawlers	Bending- and torsion-resistant welded structure fabricated from high-strength fine grain structural steel. Split-type side frames to minimise weight for transportation. Crawler pads made of heat-treated high-strength cast steel. 15 rollers per crawler with hardened rolling surfaces. Centralised lubrication included as standard.
Drive	Each crawler is powered by two hydraulic motors through closed planetary gear reduction units running in oil bath, equipped with spring-applied, hydraulically released holding brakes. As a result of their extremely compact design, the gear units fit into the width of the crawlers. Each crawler provides independent, infinitely variable control and counter-rotation capability.
Slew unit	Four slew gearboxes in carbody powered by hydraulic motors through closed planetary gear units running in oil bath. Spring-applied, hydraulically released holding brake and non-wearing hydraulic braking.

SUPERSTRUCTURE

Counterweight	235 t (295 t with 60 t central ballast in place).
Frame	Torsion-resistant welded structure fabricated from high-strength fine grain structural steel. Longitudinal beam construction to accommodate 3 rope drums and boom hoist. Split-type superstructure for ease of transportation. Hoists H1, H2 and optional H3 are pin-connected hydraulically to facilitate removal. Quick-connect capability and radial pinning between superstructure and carbody.
Power and control module	Two independent drive units incl. pump distribution gearbox and pumps are contained in a separate module which is connected to the side of the superstructure. Power comes from a DaimlerChrysler diesel engine type OM 502 LA. Output to DIN 70020: 380 kW (516 HP) at 2000 1/min, torque 2400 Nm at 1080 1/min. The engine complies with EUROMOT 3a, EPA T3 and Carb regulations. Pump distribution gearbox with five variable displacement axial piston pumps and gear pumps. The power and control module includes cabin, complete electrics and electric generators as standard.
Rope drums	Standard superstructure equipment includes three rope drums – hoist 1, hoist 2 and boom hoist. Rope drums powered by hydraulic motors through closed planetary gear units running in oil bath. All rope drums have spring-applied, hydraulically released multi-disc brakes and non-wearing hydraulic braking for load lowering. Rope ends of all drums provided with quick-connect rope end fittings. Hoists H1 and H2 (optional H3) are removable to minimise weight for transportation.
Control system	Demag IC-1: Electronic proportional valve pilot control integrated in stored-program control system incl. diagnostics. 2 colour monitors, load indicator operated via a touchscreen. Working speeds infinitely variable controlled by the lever position. Automatic power control for optimal utilisation of engine output.
Cabin	Spacious comfortable cab located at front end of power module. Large laminated glass for front and roof windows, computerised airconditioner as standard and self-contained hot air heater. Front console includes instrumentation and crane controls as well as two graphic displays (touchscreen type). Camera systems for monitoring the rope drums and SL ballast, hourmeter, load moment indicator, 2 working lights, bunk bed, storage cabinets and refrigerator are included as standard.
Electrical equipment	24 V system (2 batteries 12 V / 180 Ah). 3-phase alternator 24 V, 80 A. plus 3-phase generator 400 V 50 Hz 20 kVA for airconditioner, heater, lighting and multiple use on the job site. Emergency generator 400 V 50 Hz 16 kVA.

OPTIONAL EQUIPMENT

Counterweight carrier	The SL counterweight carrier with a max. total weight of 640 t is adjustable over a distance of 19 to 25 m or 24 to 30 m from the centre of rotation, and can be operated in the circular path, $\pm 30^\circ$ tailing and parallel travel modes. Deadweight 100 t, strips down to 3 components < 40 t for easy transport.
Superlift counterweights	
Hoist H3	Mounts on superstructure.

TECHNICAL DESCRIPTION
BOOM CONFIGURATIONS

General	Tubular chord lattice structure fabricated from high-strength fine grain structural steel. Walkways on boom, jib and mast. Hydraulic pinning.
SSL	108 m boom consisting of boom foot 10 m, 2 inserts 6 m, 7 inserts 12 m and boom head 2 m with 2 sheave-sets. Main boom lengths: 54-108 m
SSL /LSL	Consisting of SSL boom (heavy base length = 106 m) extended by jib sections. Main boom lengths: 114-156 m
SWSL	108 m jib consisting of adapter head for main boom, jib foot section 10 m, 2 inserts 6 m, 7 inserts 12 m and boom head from main boom. The SWSL jib mounts on the SSL boom. Jib lengths: 36-108 m Main boom lengths: 54 - 108 m Main boom angles: 45° - 88°
SFVL	12 m consisting of adapter head for main boom, jib foot section 10 m and boom head from main boom 2 m. Jib lengths: 12 m Jib angle (to boom): 13° The SFVL jib mounts on the SSL boom. Main boom lengths: 54-108 m
LF	Light fixed jib 18 m consisting of jib foot 9 m and jib top 9 m. Jib lengths: 18 m Jib angle (to boom): 20° The LF jib mounts every main boom (SSL or SSL / LSL). Main boom lengths: 54-138 m

OPTIONAL EQUIPMENT

3 m runner	Lifting capacity 60 t, mounts on boom head.
-------------------	---

TECHNISCHE BESCHREIBUNG

RAUPENUNTERWAGEN

	Der Raupenunterwagen ist 5-teilig und besteht aus einem Mittelstück, zwei Querträgern und zwei geteilten Raupenträgern. Raupenträger, Mittelstück und Querträger werden hydraulisch verbolzt. Die Spurbreite beträgt 10,5 m.
Mittelstück	Biege- und verwindungssteife Schweißkonstruktion aus hochfestem Feinkornbaustahl. Die Rollendrehverbindung sitzt am Mittelstück und ist mit Schnellspannmuttern (optional) auf einfache Weise zur Reduzierung der Transportgewichte lösbar.
Querträger	Biege- und verwindungssteife Schweißkonstruktion aus hochfestem Feinkornbaustahl mit hydraulischer Abstützung.
Raupen	Biege- und verwindungssteife Schweißkonstruktion aus hochfestem Feinkornbaustahl. Geteilter Raupenträger zur Minimierung der Transportgewichte. Bodenplatten der Raupenkettens aus vergütetem hochfestem Stahlguß. 15 Laufrollen je Raupe mit gehärteten Laufflächen. Zentralschmieranlage serienmäßig.
Antrieb	Jedes Raupenlaufwerk besitzt zwei Antriebe. Ein Antrieb besteht aus zwei Hydromotoren welche über geschlossene, ölbadgeschmierte Planetengetriebe mit federbelasteten, hydraulisch gelüfteten Haltebremsen die Vortriebskraft übertragen. Die Getriebe sind in besonders kompakter Bauform innerhalb der Raupenbreite angeordnet. Jede Seite ist stufenlos, einzeln und gegenläufig steuerbar.
Drehwerk	Vier Drehwerke im Mittelstück mit Antrieb durch Hydromotor über geschlossenes, ölbadgeschmiertes Planetengetriebe. Federbelastete, hydraulisch gelüftete Haltebremse und verschleißfreie hydraulische Bremsung.

OBERWAGEN

Gegengewicht	235 t (295 t bei angebaurem Zentralballast von 60 t).
Rahmen	Verformungssteife Schweißkonstruktion aus hochfestem Feinkornbaustahl. Die Längsträgerkonstruktion dient der Aufnahme von 3 Winden und dem Einziehwerk. Aus Transportgründen wird der Oberwagen geteilt ausgeführt. Die Hubwinden H1, H2 und optional H3 werden hydraulisch verbolzt und sind damit ausbaubar. Eine hydraulische Schnellverbindung mit Radialbolzen verbindet den Oberwagen mit dem Unterwagen.
Antriebsmodul	Zwei voneinander unabhängige Antriebseinheiten samt Pumpenverteilergetriebe und Pumpen sitzen in einem separaten Modul, das seitlich an den Oberwagen angebauret wird. Antriebstyp: DaimlerChrysler Dieselmotor Typ OM 502 LA. Leistung nach DIN 70020: 380 kW (516 PS) bei 2000 1/min, Drehmoment 2400 Nm bei 1080 1/min. Der Motor erfüllt die EUROMOT 3a, EPA T3 und Carb-Vorschriften. Pumpenverteilergetriebe mit fünf verstellbaren Axialkolbenpumpen und zusätzlichen Zahnradpumpen. Im Antriebsmodul sind serienmäßig die Kabine, die gesamte Elektrik sowie die Stromerzeuger integriert.
Seilwinden	Der Oberwagen ist serienmäßig mit drei Seilwinden – Hubwerk 1, Hubwerk 2 und Einziehwerk – ausgerüstet. Der Antrieb der Winden erfolgt durch Hydromotoren über geschlossene, ölbadgeschmierte Planetengetriebe. Alle Seilwinden sind mit federbelasteten, hydraulisch gelüfteten Lamellenbremsen und verschleißfreier, hydraulischer Bremsung für den Senkvorgang ausgerüstet. Die Seilenden aller Winden sind mit Preßfitting und Taschen ausgestattet. Zur Reduzierung der Transportgewichte sind die Winden H1 und H2 (opt. H3) ausbaubar.
Steuerung	Demag IC-1: Elektronische Proportionalventilvorsteuerung integriert in eine speicherprogrammierte Steuerung mit Fehlerdiagnose. Zwei Farbbildschirme, Bedienung über Touchscreen. Die Arbeitsgeschwindigkeiten werden durch die Hebelstellung stufenlos geregelt. Leistungsregelung der Antriebe zur optimalen Nutzung der Motorleistung.
Kabine	Die geräumige Komfortkabine ist im vorderen Bereich des Antriebsmoduls angeordnet. Sie ist mit großzügiger Sicherheitsverglasung auch im Dachbereich, computergesteuerter Klimaanlage serienmäßig und motorunabhängiger Warmluftheizung ausgestattet. Steuer- und Kontrollelemente für die Kranfunktionen sowie zwei Grafik-Displays befinden sich in der Frontkonsole. Kamerasysteme für die Überwachung von Winden und SL-Ballast, Betriebsstundenzähler, Lastmomentanzeige, 2 Arbeitsscheinwerfer sowie Klappbett, Ablageschränke und Kühlschränke sind serienmäßig.
Elektrische Anlage	24 V System (2 x Batterie 12 V / 180 Ah). 3-Phasen Wechselstromgenerator 24 V, 80 A. zusätzlich 3-Phasengenerator 400 V 50 Hz 20 KVA für Klimaanlage, Heizung, Beleuchtung und vielfältige Anwendungen auf der Baustelle. Notstromaggregat 400 V 50 Hz 16 KVA.

ZUSATZAUSRÜSTUNG

Gegengewichtswagen	Der Gegengewichtswagen mit max. Gesamtgewicht von 640 t kann im Abstand von 19 bis 25 m oder 24 bis 30 m zur Drehmitte frei verstellbar und in den Fahrzuständen Drehen, Hinterherfahrt und Nachlauf $\pm 30^\circ$ betrieben werden. Eigengewicht 100 t, zum Transport in 3 Komponenten < 40 t zerlegbar.
Superlift-Gegengewichte	
Hubwerk H3	Wird im Oberwagen eingebaut.

TECHNISCHE BESCHREIBUNG
AUSLEGERVARIANTEN

Allgemein	Gitter-Rohrkonstruktion aus hochfestem Feinkornbaustahl. Begehungen auf Hauptausleger, Hilfsausleger und Superlift-Mast. Hydraulische Verbolzungen.
SSL	108 m Ausleger bestehend aus Hauptauslegerfuß 10 m, 2 Zwischenstücken 6 m, 7 Zwischenstücken 12 m und Rollenkopf 2 m mit 2 Rollensätzen. Hauptauslegerlängen: 54-108 m
SSL /LSL	Bestehend aus SSL-Ausleger (schwere Grundlänge = 106 m) verlängert mit Hilfsauslegerteilen. Hauptauslegerlängen: 114-156 m
SWSL	108 m Hilfsausleger bestehend aus Anschlußkopf Hauptausleger, Hilfsauslegerfuß 10 m, 2 Zwischenstücken 6 m, 7 Zwischenstücken 12 m und Rollenkopf. Der Hilfsausleger SWSL wird auf den Hauptausleger SSL montiert. Hilfsauslegerlängen: 36-108 m Hauptauslegerlängen: 54-108 m Hauptauslegerwinkel: 45° - 88°
SFVL	Vessel-Lift Hilfsausleger 12 m bestehend aus Hilfsauslegerfuß 10 m und Rollenkopf 2 m. Hilfsauslegerlängen: 12 m Hauptauslegerwinkel: 13° Der Hilfsausleger SFVL wird auf den Hauptausleger SSL montiert. Hauptauslegerlängen: 54-108 m
LF	Leichter starrer Hilfsausleger 18 m bestehend aus Fuß 9 m und Spitze 9 m. Hilfsauslegerlängen: 18 m Hauptauslegerwinkel: 20° Der Hilfsausleger LF wird auf den Hauptausleger SSL oder SSL /LSL montiert. Hauptauslegerlängen: 54-138 m

ZUSATZAUSRÜSTUNG

Runner 3 m	Tragfähigkeit 60 t, Anbau an Rollenkopf.
-------------------	--

DESCRIPTIF TECHNIQUE

CHÂSSIS À CHENILLES

	Le porteur à chenilles est réalisé en 5 parties et se compose d'une partie centrale, de deux traverses et de deux trains de chenilles divisibles en deux parties. Les trains de chenilles, la partie centrale et les traverses sont verrouillés hydrauliquement. La voie est de 10,5 m.
Partie centrale	Structure mécano-soudée rigide à la flexion et à la torsion, réalisée en acier de construction à grains fins à haute résistance. Ecrous à serrage rapide (en option) facilitant le démontage de la couronne d'orientation pour réduire les poids de transport.
Traverses	Structure mécano-soudée rigide à la flexion et à la torsion, réalisée en acier de construction à grains fins à haute résistance, avec calage hydraulique.
Chenilles	Structure mécano-soudée rigide à la flexion et à la torsion, réalisée en acier de construction à grains fins à haute résistance. Trains de chenilles divisibles pour minimiser les poids de transport. Patins de chenilles en acier coulé trempé et revenu à haute résistance. 15 galets par chenille avec surfaces de roulement trempées. Graissage centralisé de série.
Entraînement	Chaque barbotin est entraîné par deux moteurs hydrauliques avec réducteurs planétaires en carter étanche sous bain d'huile, munis de freins d'arrêt à ressorts à desserrage hydraulique. Grâce à leur compacité, les réducteurs s'intègrent complètement dans la largeur des chenilles. Chaque côté permet un mouvement réglable sans paliers individuel et dans le sens opposé.
Mécanisme d'orientation	Quatre mécanismes d'orientation dans la partie centrale entraînés par moteurs hydrauliques avec réducteurs planétaires en carter étanche sous bain d'huile. Freins d'arrêt à ressorts à desserrage hydraulique et freinage anti-usure hydraulique.

PARTIE SUPÉRIEURE

Contrepoids	235 t (295 t avec 60 t de lest central monté).
Charpente	Structure mécano-soudée résistant à la déformation, réalisée en acier de construction à grains fins à haute résistance. Structure à longerons servant à recevoir 3 treuils et le mécanisme de relevage. La partie supérieure est divisible en deux parties pour des raisons de transport. Les treuils H1, H2 et H3 en option sont verrouillés hydrauliquement pour faciliter le démontage. Connexion rapide à verrouillage radial servant de jonction entre la partie tournante et le châssis.
Module de motorisation et de commande	Deux unités d'entraînement indépendantes l'une de l'autre, y compris la boîte de transfert à pompes et les pompes, sont disposées dans un module séparé attaché latéralement à la partie tournante. Type de motorisation : moteur diesel DaimlerChrysler type OM 502 LA. Puissance selon DIN 70020 : 380 kW (516 CV) à 2000 1/min, couple 2400 Nm à 1080 1/min. Le moteur satisfait aux règlements EUROMOT 3a, EPA T3 et Carb. Boîte de transfert à cinq pompes à pistons axiaux à débit variable et pompes à engrenage auxiliaires. La cabine, tout le système électrique et les équipements de génération de courant sont logés de série dans le module de motorisation et de commande.
Treuils	La partie supérieure est équipée de série de trois treuils – le treuil 1, le treuil 2 et le mécanisme de relevage. L'entraînement des treuils s'effectue par des moteurs hydrauliques avec réducteurs planétaires en carter étanche sous bain d'huile. Tous les treuils sont équipés de freins à disques multiples à ressorts à desserrage hydraulique et d'un freinage anti-usure hydraulique pour la descente. Les extrémités des câbles de tous les treuils sont munies des attaches à jonction rapide. Les treuils H1 et H2 (H3 en option) sont démontables pour réduire les poids de transport.
Commande	Demag IC-1 : Pilotage électronique de soupapes proportionnelles intégré dans un automate programmable avec diagnostic de dysfonctionnement. 2 écrans couleur, commande du C.E.C. par écran tactile. Les vitesses de travail sont réglées sans paliers par la position du levier. Régulation automatique pour une exploitation optimale de la puissance du moteur.
Cabine	La cabine spacieuse et confortable est placée à la partie avant du module de motorisation et de commande. Large pare-brise et toit en vitrage blindé, climatisation commandée par ordinateur de série et chauffage à air chaud indépendant du moteur. Console frontale avec éléments de commande et de contrôle pour les fonctions de la grue ainsi que deux affichages graphiques. Systèmes de caméra pour surveiller les treuils et lest SL, compteur d'heures de service, affichage du moment de charge, 2 projecteurs de travail, lit pliant, armoires de rangement et réfrigérateur livrés de série.
Installation électrique	Système 24 V (2 batteries 12 V / 180 Ah). Génératrice à courant alternatif triphasé 24 V, 80 A. Génératrice triphasée supplémentaire à 400 V 50 Hz 20 kVA pour la climatisation, le chauffage, l'éclairage et de multiples applications sur le chantier. Groupe électrogène de secours 400 V 50 Hz 16 kVA.

EQUIPEMENTS OPTIONNELS

Chariot contrepoids	Le chariot contrepoids SL avec un poids total maxi de 640 t peut être librement ajusté sur une distance comprise entre 19 et 25 m ou entre 24 et 30 m du centre de rotation et peut être opéré dans les modes de déplacement du genre circulaire, marche derrière $\pm 30^\circ$ et marche en parallèle. Poids mort 100 t, démontable en 3 parties < 40 t pour un transport facile.
Contrepoids Superlift	
Treuil H3	Montage sur la partie tournante.

DESCRIPTIF TECHNIQUE
COMBINAISONS DE FLÈCHE

Général	Construction tubulaire treillie en acier de haute résistance à grains fins. Passerelles sur flèche principale, volée variable et mât superlift. Verrouillage hydraulique.
SSL	108 m flèche se composant de: pied de flèche principale 10 m, 2 pièces intermédiaires 6 m, 7 pièces intermédiaires 12 m et tête de flèche 2 m avec 2 jeux de poulies. Longueur de flèche principale: 54-108 m
SSL /LSL	Se composant de la flèche SSL (longueur lourde de base = 106 m) rallongée par des pièces de la volée variable. Longueur de flèche principale: 114-156 m
SWSL	108 m de volée variable se composant de: tête de flèche principale (de connexion), pied de volée variable 10 m, 2 pièces intermédiaires 6 m, 7 pièces intermédiaires 12 m et tête de flèche. La volée variable SWSL est montée sur la flèche principale SSL. Longueur de volée variable: 36-108 m Longueur de flèche principale: 54-108 m Angle de la flèche principale: 45° - 88°
SFVL	Flèche Vessel-Lift 12 m se composant de: pied de volée variable 10 m et tête de flèche 2 m. Longueur de volée variable: 12 m Angle de la flèche principale: 13° La volée variable SFVL est montée sur la flèche principale SSL. Longueur de flèche principale: 54-108 m
LF	Fléchette fixe légère 18 m se composant de: pied 9 m et pointe 9 m. Longueur de volée variable: 18 m Angle de la flèche principale: 20° La fléchette fixe LF se monte sur la flèche principale SSL ou SSL/LSL Longueur de flèche principale: 54-138 m

EQUIPEMENTS OPTIONNELS

Potence de 3 m	Capacité de levage de 60 t, montage en tête de flèche.
-----------------------	--

**NOTES TO LIFTING CAPACITY · ANMERKUNGEN ZU DEN TRAGFÄHIGKEITEN ·
CONDITIONS D'UTILISATION**

Ratings are in compliance with ISO 4305 and DIN 15019.2 (test load = 1.25 x suspended load + 0.1 x dead weight of boom head).
Weight of hook blocks and slings is part of the load, and is to be deducted from the capacity ratings.

Consult operation manual for further details.

Note: Data published herein is intended as a guide only and shall not be construed to warrant applicability for lifting purposes.
Crane operation is subject to the computer charts and operation manual both supplied with the crane.

In some instances the superlift counterweight does not lift off the ground with the indicated load.

Tragfähigkeiten entsprechen ISO 4305 und DIN 15019.2 (Prüflast = 1,25 x Hublast + 0,1 x Kopfgewicht).

Das Gewicht der Unterflaschen, sowie die Lastaufnahmemittel, sind Bestandteile der Last und sind von den Tragfähigkeitsangaben abzuziehen.

Weitere Angaben in der Bedienungsanleitung des Kranes.

Anmerkung: Die Daten dieser Broschüre dienen nur zur allgemeinen Information; für ihre Richtigkeit übernehmen wir keine Haftung.
Der Betrieb des Kranes ist nur mit den Original-Tragfähigkeitstabellen und mit der Bedienungsanleitung zulässig, die mit dem Kran mitgeliefert werden.

In einigen Fällen hebt das Superliftgegengewicht bei den angegebenen Traglasten nicht ab.

Le tableau de charges est conforme à la norme ISO 4305 et DIN 15019.2 (charge d'essai = 1,25 x charge suspendue + 0,1 x poids de la tête de flèche).

Les poids du crochet-moufle et de tous les accessoires d'élingage font partie de la charge et sont à déduire des charges indiquées.

Pour plus de détails consulter la notice d'utilisation de la grue.

Nota: Les renseignements ci-inclus sont donnés à titre indicatif et ne représentent aucune garantie d'utilisation pour les opérations de levage.
La mise en service de la grue n'est autorisée qu'à condition que les tableaux de charges ainsi que le manuel de service, tels que fournis avec la grue, soient observés.

Le contrepoids du superlift ne décolle pas dans certaines configurations des tableaux de charge.

KEY · ZEICHENERKLÄRUNG · LÉGENDE
 Track · Spur · Voie

Counterweight + central ballast (ZB) · Gegengewicht + Zentralballast (ZB) · Contrepoids + lest central (ZB)



Superlift counterweight · Superlift-Gegengewicht · Contrepoids Superlift



Superlift radius · Superlift-Radius · rayon Superlift



Load radius · Lastradius · Portée



Main boom · Hauptausleger · Flèche principale



Fly jib · Hilfsausleger · Fléchette



Main boom angle · Hauptauslegerwinkel · Jarret de flèche principale



Fly jib angle · Hilfsauslegerwinkel · Jarret de fléchette

„D“

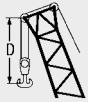

S: heavy · schwer · lourd

L: light · leicht · léger

H: Main boom · Hauptausleger · Flèche principale

W: Luffing fly jib · Wippbarer Hilfsausleger · Fléchette à volée variable

F: Fixed fly jib · Starrer Hilfsausleger · Fléchette fixe

SL: Superlift

SGL: Heavy base length · Schwere Grundlänge · Longueur de base lourde

Effective Date: April 2007.

Product specifications and prices are subject to change without notice or obligation. The photographs and/or drawings in this document are for illustrative purposes only. Refer to the appropriate Operator's Manual for instructions on the proper use of this equipment. Failure to follow the appropriate Operator's Manual when using our equipment or to otherwise act irresponsibly may result in serious injury or death. The only warranty applicable to our equipment is the standard written warranty applicable to the particular product and sale and Terex makes no other warranty, express or implied.

Products and services listed may be trademarks, service marks or trade-names of Terex Corporation and/or its subsidiaries in the USA and other countries and all rights are reserved.

„TEREX“ is a registered trademark of Terex Corporation in the USA and many other countries.

Copyright © 2007 Terex Corporation.

Gültig ab: April 2007.

Produktbeschreibungen und Preise können jederzeit und ohne Verpflichtung zur Ankündigung geändert werden. Die in diesem Dokument enthaltenen Fotos und/oder Zeichnungen dienen rein anschaulichen Zwecken. Anweisungen zur ordnungsgemäßen Verwendung dieser Ausrüstung entnehmen Sie bitte dem zugehörigen Betriebshandbuch. Nichtbefolgung des Betriebshandbuchs bei der Verwendung unserer Produkte oder anderweitig fahrlässiges Verhalten kann zu schwerwiegenden Verletzungen oder Tod führen. Für dieses Produkt wird ausschließlich die entsprechende, schriftlich niedergelegte Standardgarantie gewährt. Terex leistet keinerlei darüber hinaus gehende Garantie, weder ausdrücklich noch stillschweigend.

Die Bezeichnungen der aufgeführten Produkte und Leistungen sind gegebenenfalls Marken, Servicemarken oder Handelsnamen der Terex Corporation und/oder ihrer Tochtergesellschaften in den USA und anderen Ländern. Alle Rechte vorbehalten.

„TEREX“ ist eine eingetragene Marke der Terex Corporation in den USA und vielen anderen Ländern.

Copyright © 2007 Terex Corporation.

Date d'effet : le avril 2007.

Les spécifications et prix des produits sont sujets à modification sans avis ou obligation. Les photographies et/ou dessins contenus dans ce documents sont uniquement pour illustration. Veuillez vous référer à la notice d'utilisation appropriée pour les instructions quant à l'utilisation correcte de cet équipement. Tout manquement au suivi de la notice d'utilisation appropriée lors de l'utilisation de notre équipement ou tout acte autrement irresponsable peut résulter en blessure corporelle sérieuse ou mortelle. La seule garantie applicable à notre équipement est la garantie standard écrite applicable à un produit et à une vente spécifique. Terex n'offre aucune autre garantie, expresse ou explicite.

Les produits et services proposés peuvent être des marques de fabrique, des marques de service ou des appellations commerciales de Terex Corporation et/ou ses filiales aux Etats Unis et dans les autres pays, et tous les droits sont réservés.

«TEREX» est une marque déposée de Terex Corporation aux Etats Unis et dans de nombreux autres pays.

Copyright © 2007 Terex Corporation.